

## FNS – Flange, normal, standard height R1651 ... 2.

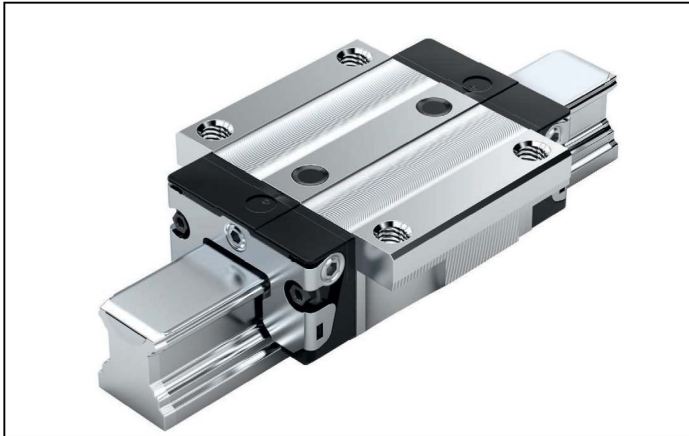

### Dynamic characteristics

Travel speed:  $v_{\max} = 5 \text{ m/s}$

Acceleration:  $a_{\max} = 500 \text{ m/s}^2$

(If  $F_{\text{comb}} > 2.8 \cdot F_{\text{pr}}$ :  $a_{\max} = 50 \text{ m/s}^2$ )

### Note on lubrication

► Pre-lubricated

### Note

For all SNS/SNO ball guide rails.

### Options and part numbers

Size	Ball runner block with size	Preload class				Accuracy class						Seal with ball runner blocks						
		C0	C1	C2	C3	N	H	P	XP	SP	UP	without ball chain			with ball chain			
												SS	LS <sup>1)</sup>	DS	SS	LS <sup>1)</sup>	DS	
15	R1651 1	9				4	3	-	-	-	-	20	21	-	22	23	-	-
			1			4	3	2	8	1	9	20	21	-	22	23	-	-
				2		-	3	2	8	1	9	20	21	-	22	23	-	-
					3	-	-	-	8	1	9	20	21	-	22	23	-	-
20	R1651 8	9				4	3	-	-	-	-	20	21	-	22	23	-	-
			1			4	3	2	8	1	9	20	21	2Z	22	23	2Y	-
				2		-	3	2	8	1	9	20	21	2Z	22	23	2Y	-
					3	-	-	-	8	1	9	20	21	2Z	22	23	2Y	-
25	R1651 2	9				4	3	-	-	-	-	20	21	-	22	23	-	-
			1			4	3	2	8	1	9	20	21	2Z	22	23	2Y	-
				2		-	3	2	8	1	9	20	21	2Z	22	23	2Y	-
					3	-	-	-	8	1	9	20	21	2Z	22	23	2Y	-
30	R1651 7	9				4	3	-	-	-	-	20	21	-	22	23	-	-
			1			4	3	2	8	1	9	20	21	2Z	22	23	2Y	-
				2		-	3	2	8	1	9	20	21	2Z	22	23	2Y	-
					3	-	-	-	8	1	9	20	21	2Z	22	23	2Y	-
35	R1651 3	9				4	3	-	-	-	-	20	21	-	22	23	-	-
			1			4	3	2	8	1	9	20	21	2Z	22	23	2Y	-
				2		-	3	2	8	1	9	20	21	2Z	22	23	2Y	-
					3	-	-	-	8	1	9	20	21	2Z	22	23	2Y	-
45	R1651 4	9				4	3	-	-	-	-	20	-	-	22	-	-	-
			1			4	3	2	8	1	9	20	-	2Z	22	-	2Y	-
				2		-	3	2	8	1	9	20	-	2Z	22	-	2Y	-
					3	-	-	-	8	1	9	20	-	2Z	22	-	2Y	-
e.g.	R1651 7		1			3						20						

1) With accuracy classes N and H and XP in preload class C1 only.

### Order example

Options:

- FNS ball runner block
- Size 30
- Preload class C1
- Accuracy class H
- With standard seal, without ball chain

Part number:

R1651 713 20

### Preload classes

C0 = Without preload (clearance)  
 C1 = Moderate preload  
 C2 = Average preload  
 C3 = High preload

### Seals

SS = standard seal  
 LS = low-friction seal  
 DS = double-lipped seal

### Key

Gray digits  
 = No preferred variant/combination  
 (Some delivery times may be longer)

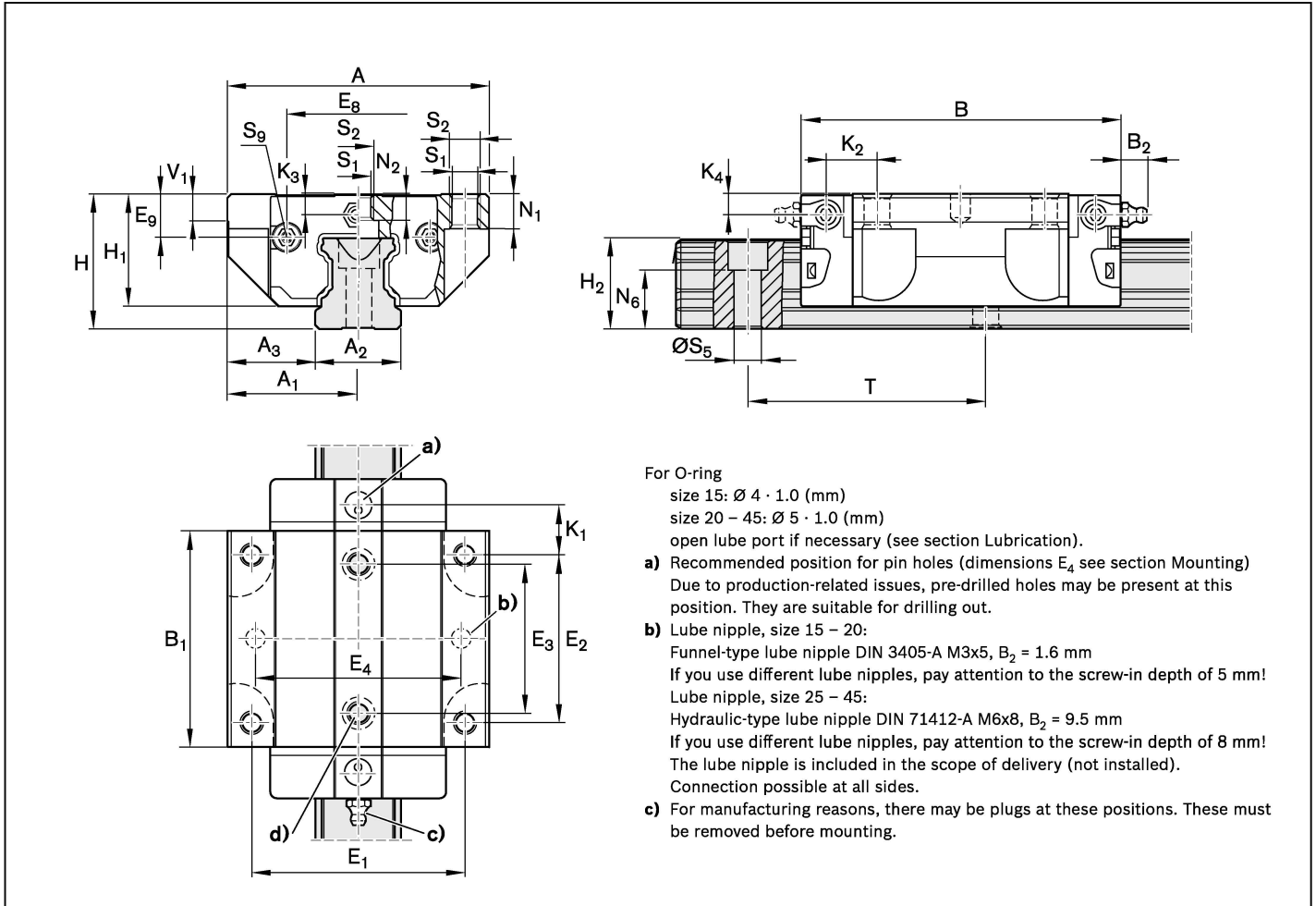

Size	Dimensions (mm)																		
	A	A <sub>1</sub>	A <sub>2</sub>	A <sub>3</sub>	B <sup>+0.5</sup>	B <sub>1</sub>	E <sub>1</sub>	E <sub>2</sub>	E <sub>3</sub>	E <sub>8</sub>	E <sub>9</sub>	H	H <sub>1</sub>	H <sub>2</sub> <sup>1)</sup>	H <sub>2</sub> <sup>2)</sup>	K <sub>1</sub>	K <sub>2</sub>	K <sub>3</sub>	K <sub>4</sub>
15	47	23.5	15	16.0	58.2	39.2	38	30	26	24.55	6.70	24	19.90	16.30	16.20	8.00	9.6	3.20	3.20
20	63	31.5	20	21.5	75.0	49.6	53	40	35	32.50	7.30	30	25.35	20.75	20.55	11.80	11.8	3.35	3.35
25	70	35.0	23	23.5	86.2	57.8	57	45	40	38.30	11.50	36	29.90	24.45	24.25	12.45	13.6	5.50	5.50
30	90	45.0	28	31.0	97.7	67.4	72	52	44	48.40	14.60	42	35.35	28.55	28.35	14.00	15.7	6.05	6.05
35	100	50.0	34	33.0	110.5	77.0	82	62	52	58.00	17.35	48	40.40	32.15	31.85	14.50	16.0	6.90	6.90
45	120	60.0	45	37.5	137.6	97.0	100	80	60	69.80	20.90	60	50.30	40.15	39.85	17.30	19.3	8.20	8.20

Size	Dimensions (mm)										Weight (kg)	Load capacities <sup>3)</sup> (N)		Load moments <sup>3)</sup> (Nm)			
	N <sub>1</sub>	N <sub>2</sub>	N <sub>6</sub> <sup>±0.5</sup>	S <sub>1</sub>	S <sub>2</sub>	S <sub>5</sub>	S <sub>9</sub>	T	V <sub>1</sub>	m		C	C <sub>0</sub>	M <sub>t</sub>	M <sub>t0</sub>	M <sub>L</sub>	M <sub>L0</sub>
15	5.2	4.40	10.3	4.3	M5	4.5	M2.5x3.5	60	5.0	0.20	9 860	12 700	95	120	68	87	
20	7.7	5.20	13.2	5.3	M6	6.0	M3x5	60	6.0	0.45	23 400	29 800	300	380	200	260	
25	9.3	7.00	15.2	6.7	M8	7.0	M3x5	60	7.5	0.65	28 600	35 900	410	510	290	360	
30	11.0	7.90	17.0	8.5	M10	9.0	M3x5	80	7.0	1.10	36 500	48 100	630	830	440	580	
35	12.0	10.15	20.5	8.5	M10	9.0	M3x5	80	8.0	1.60	51 800	80 900	1 110	1 740	720	1 130	
45	15.0	12.40	23.5	10.4	M12	14.0	M4x7	105	10.0	3.00	86 400	132 000	2 330	3 560	1 540	2 350	

- 1) Dimension H<sub>2</sub> with cover strip
- 2) Dimension H<sub>2</sub> without cover strip
- 3) Load capacities and load moments for ball runner blocks **without** ball chain. Load capacities and load moments for ball runner blocks **with** ball chain 12  
 Determination of the dynamic load capacities and load moments is based on a 100,000 m travel life according to DIN ISO14728-1. Often only 50,000 m are actually stipulated. For comparison: Multiply values C, M<sub>t</sub> and M<sub>L</sub> by 1.26 according to the table.