

FIXING CLIPS

ALWAYS provide a complete range of fixing clips designed specially for use with their ball transfer units.

They lock the unit securely in position without the need for special tools or machinery.

Some standard clips are described here. Special designs can also be provided, please ask for details.

The effectiveness and security of ball units attached by means of fixing clips can be influenced by size of fixing holes, table thickness and ball unit tolerances.

CL11 (stock item)

Available in three sizes only to suit ball units with body diameters of 36mm, 45mm and 62mm.

CL12 (made to order)

This clip will fit under the flange of any of our ball units that have parallel sides. If any particular size of clip is not in stock there may be a minimum order charge. Fixing hole sizes on application.

On certain units it is possible to machine a recess to retain the clip in the body of the ball unit. These units must have a solid steel body, are not stock items and are only manufactured to specific orders.

CL13 (stock item)

These are to be used with ball units with a body diameter of 24mm only.

CL14 (stock item)

Stocked for body diameter of 24mm, 36mm, 45mm and 62mm. This clip was designed for fixing ball units from the top face of a ball platform. The clip can also be used for fixing the ball unit from underneath the ball platform if clip CL11 is not suitable. The preferred table top material thickness for maximum effectiveness of the CL14 range of clips is 2mm to 4mm. The CL14 fixing clips can be used for thicker materials with a slight reduction in clip effectiveness. For maximum clip effectiveness the seating hole size should be on the minimum tolerance and the table top material thickness should be 4mm. Please see page 17 for seating hole sizes

CL14 fixing clips must be placed into the seating hole first, before the ball unit is fitted.

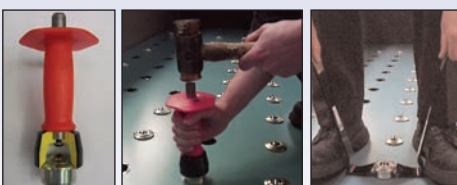

CL11

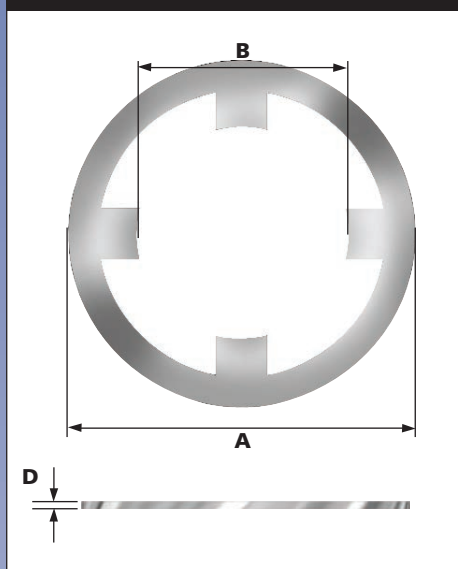

CL12



CL13

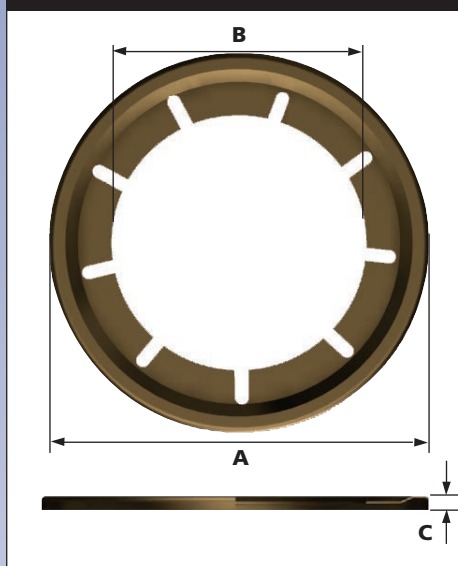

CL14

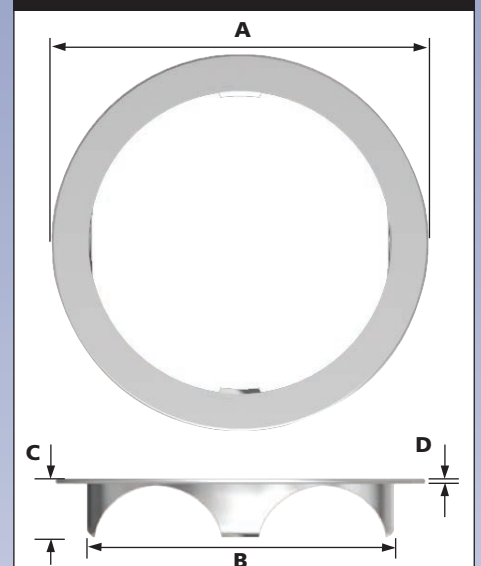

CL15 (made to order)

A circlip type clip used mainly for solid machined body units. The circlip is fitted from underneath the ball unit and is available in many sizes.

Ball units with circlip grooves are not ex stock items. The standard circlip is self colour spring steel, but plated circlips can be offered where corrosion resistance is required.

FITTING CL12 AND CL14 FIXING CLIPS

When fitting ball units with CL12 or CL14 fixing clips, do not strike the load ball to press the unit into position.



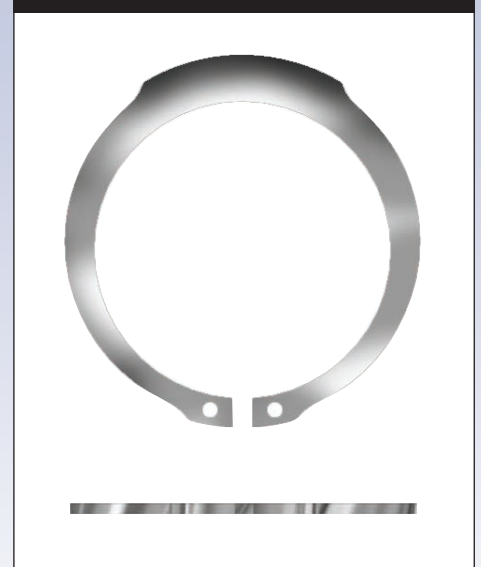

Instead, apply an even force onto the ball unit's body using a tube or similar tool.

Installation and removal tools can be supplied to ensure the correct installation of ball transfer units for the CL12 and CL14 fixing clip range. Details of the installation and removal tools are available upon request.

CL15

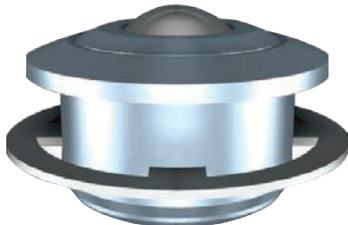



REF No																																															
CL11	 <p>Material: Stainless Steel AISI 304 Finish: Self Colour</p>	<table border="1"> <thead> <tr> <th>Ref No.</th> <th>Flange diameter A</th> <th>Inside diameter B</th> <th>Material Thickness D</th> </tr> </thead> <tbody> <tr> <td>CL11-22</td> <td>Ø71.1</td> <td>Ø35.9</td> <td>0.7</td> </tr> <tr> <td>CL11-30</td> <td>Ø71.1</td> <td>Ø44.9</td> <td>0.7</td> </tr> <tr> <td>CL11-45</td> <td>Ø72.6</td> <td>Ø61.2</td> <td>0.7</td> </tr> </tbody> </table> <p>CL11 CLIP TO BE USED WITH THE FOLLOWING BALL UNITS</p> <table border="1"> <thead> <tr> <th>CL11-22</th> <th>CL11-30</th> <th>CL11-45</th> </tr> </thead> <tbody> <tr> <td>522-0, 522-4 and 522-6 (pages 16 & 17)</td> <td>530-0, 530-4 and 530-6 (pages 16 & 17)</td> <td>545-0, 545-4 and 545-6 (pages 16 & 17)</td> </tr> <tr> <td>800-22 and 810-22 (pages 18 & 19)</td> <td>800-30, 805-30 806-30, 807-30 and 810-30 (pages 18 & 19)</td> <td>800-45, 80545 and 810-45 (pages 18 & 19)</td> </tr> </tbody> </table>	Ref No.	Flange diameter A	Inside diameter B	Material Thickness D	CL11-22	Ø71.1	Ø35.9	0.7	CL11-30	Ø71.1	Ø44.9	0.7	CL11-45	Ø72.6	Ø61.2	0.7	CL11-22	CL11-30	CL11-45	522-0, 522-4 and 522-6 (pages 16 & 17)	530-0, 530-4 and 530-6 (pages 16 & 17)	545-0, 545-4 and 545-6 (pages 16 & 17)	800-22 and 810-22 (pages 18 & 19)	800-30, 805-30 806-30, 807-30 and 810-30 (pages 18 & 19)	800-45, 80545 and 810-45 (pages 18 & 19)																				
		Ref No.	Flange diameter A	Inside diameter B	Material Thickness D																																										
CL11-22	Ø71.1	Ø35.9	0.7																																												
CL11-30	Ø71.1	Ø44.9	0.7																																												
CL11-45	Ø72.6	Ø61.2	0.7																																												
CL11-22	CL11-30	CL11-45																																													
522-0, 522-4 and 522-6 (pages 16 & 17)	530-0, 530-4 and 530-6 (pages 16 & 17)	545-0, 545-4 and 545-6 (pages 16 & 17)																																													
800-22 and 810-22 (pages 18 & 19)	800-30, 805-30 806-30, 807-30 and 810-30 (pages 18 & 19)	800-45, 80545 and 810-45 (pages 18 & 19)																																													
CL12	 <p>Material: Stainless Steel Spring Steel Finish: Self Colour</p>	<p>CL12 CLIP TO BE USED WITH THE FOLLOWING BALL UNITS</p> <table border="1"> <tbody> <tr> <td>1007 (Pages 8 & 9)</td> <td>515-0, 515-4, 515-6 522-0, 522-4, 522-6 530-0, 530-4, 530-6 545-0, 545-4, 545-6 (Pages 16 & 17)</td> <td>6025-2 and 6025-4 (Pages 20 & 21)</td> <td>7104, 7124 7125, 7152 and 7171 (Pages 22 & 23)</td> </tr> <tr> <td>0519-22, 3019-22 1019-22, 1029-22 and 2019-22 (Pages 28 & 29)</td> <td>810-15, 800-22 810-22, 800-30 805-30, 810-30 800-45, 805-45 806-30, 807-30 810-45 and 800-60 (Pages 18 & 19)</td> <td>3010, 3011, 1017 1018, 1509, 1507 1027, 1028, 2009 2010, 4007 and 4008 (Pages 26 & 27)</td> <td></td> </tr> </tbody> </table> <p>CL12 fixing clip sizes available upon request</p>	1007 (Pages 8 & 9)	515-0, 515-4, 515-6 522-0, 522-4, 522-6 530-0, 530-4, 530-6 545-0, 545-4, 545-6 (Pages 16 & 17)	6025-2 and 6025-4 (Pages 20 & 21)	7104, 7124 7125, 7152 and 7171 (Pages 22 & 23)	0519-22, 3019-22 1019-22, 1029-22 and 2019-22 (Pages 28 & 29)	810-15, 800-22 810-22, 800-30 805-30, 810-30 800-45, 805-45 806-30, 807-30 810-45 and 800-60 (Pages 18 & 19)	3010, 3011, 1017 1018, 1509, 1507 1027, 1028, 2009 2010, 4007 and 4008 (Pages 26 & 27)																																						
		1007 (Pages 8 & 9)	515-0, 515-4, 515-6 522-0, 522-4, 522-6 530-0, 530-4, 530-6 545-0, 545-4, 545-6 (Pages 16 & 17)	6025-2 and 6025-4 (Pages 20 & 21)	7104, 7124 7125, 7152 and 7171 (Pages 22 & 23)																																										
0519-22, 3019-22 1019-22, 1029-22 and 2019-22 (Pages 28 & 29)	810-15, 800-22 810-22, 800-30 805-30, 810-30 800-45, 805-45 806-30, 807-30 810-45 and 800-60 (Pages 18 & 19)	3010, 3011, 1017 1018, 1509, 1507 1027, 1028, 2009 2010, 4007 and 4008 (Pages 26 & 27)																																													
CL13	 <p>Material: Carbon Spring Steel Finish: Bronze Finish</p>	<table border="1"> <thead> <tr> <th>Ref No.</th> <th>Flange diameter A</th> <th>Inside diameter B</th> <th>Length C</th> </tr> </thead> <tbody> <tr> <td>CL13-15</td> <td>Ø41.4</td> <td>Ø23.4</td> <td>3.2</td> </tr> </tbody> </table> <p>The CL13-15 fixing clip can be used with the 515-0, 515-4 and 515-6 ball units (pages 16-17) and also the 810-15 ball unit (pages 18 and 19).</p>	Ref No.	Flange diameter A	Inside diameter B	Length C	CL13-15	Ø41.4	Ø23.4	3.2																																					
		Ref No.	Flange diameter A	Inside diameter B	Length C																																										
CL13-15	Ø41.4	Ø23.4	3.2																																												
CL14	 <p>Material: Carbon Spring Steel Finish: Zinc Plated Please see page 17 for seating hole sizes</p>	<table border="1"> <thead> <tr> <th>Ref No.</th> <th>Flange diameter A</th> <th>Body outside diameter B</th> <th>Length C</th> <th>Material Thickness D</th> </tr> </thead> <tbody> <tr> <td>CL14-15</td> <td>Ø30.9</td> <td>Ø24.7</td> <td>6.0</td> <td>0.3</td> </tr> <tr> <td>CL14-22</td> <td>Ø44.5</td> <td>Ø36.7</td> <td>7.0</td> <td>0.3</td> </tr> <tr> <td>CL14-30</td> <td>Ø54.9</td> <td>Ø45.7</td> <td>7.0</td> <td>0.3</td> </tr> <tr> <td>CL14-45</td> <td>Ø74.0</td> <td>Ø62.7</td> <td>7.0</td> <td>0.3</td> </tr> </tbody> </table> <p>CL14 CLIP TO BE USED WITH THE FOLLOWING BALL UNITS</p> <table border="1"> <thead> <tr> <th>CL14-15</th> <th>CL14-22</th> <th>CL14-30</th> <th>CL14-45</th> </tr> </thead> <tbody> <tr> <td>515-0, 515-4 and 515-6 (pages 16 & 17)</td> <td>522-0, 522-4 and 522-6 (pages 16 & 17)</td> <td>530-0, 530-4 and 530-6 (pages 16 & 17)</td> <td>545-0, 545-4 and 545-6 (pages 16 & 17)</td> </tr> <tr> <td>7104 (pages 22 & 23)</td> <td>800-22, 810-22 (pages 18 & 19)</td> <td>800-30, 805-30, 806-30 807-30 and 810-30 (pages 18 & 19)</td> <td>800-45, 805-45 and 810-45 (pages 18 & 19)</td> </tr> <tr> <td>810-15 (pages 18 & 19)</td> <td></td> <td>1017, 1018, 1507 and 1509 (pages 26 & 27)</td> <td></td> </tr> <tr> <td></td> <td></td> <td>7124 (pages 22 & 23)</td> <td></td> </tr> </tbody> </table>	Ref No.	Flange diameter A	Body outside diameter B	Length C	Material Thickness D	CL14-15	Ø30.9	Ø24.7	6.0	0.3	CL14-22	Ø44.5	Ø36.7	7.0	0.3	CL14-30	Ø54.9	Ø45.7	7.0	0.3	CL14-45	Ø74.0	Ø62.7	7.0	0.3	CL14-15	CL14-22	CL14-30	CL14-45	515-0, 515-4 and 515-6 (pages 16 & 17)	522-0, 522-4 and 522-6 (pages 16 & 17)	530-0, 530-4 and 530-6 (pages 16 & 17)	545-0, 545-4 and 545-6 (pages 16 & 17)	7104 (pages 22 & 23)	800-22, 810-22 (pages 18 & 19)	800-30, 805-30, 806-30 807-30 and 810-30 (pages 18 & 19)	800-45, 805-45 and 810-45 (pages 18 & 19)	810-15 (pages 18 & 19)		1017, 1018, 1507 and 1509 (pages 26 & 27)				7124 (pages 22 & 23)	
		Ref No.	Flange diameter A	Body outside diameter B	Length C	Material Thickness D																																									
CL14-15	Ø30.9	Ø24.7	6.0	0.3																																											
CL14-22	Ø44.5	Ø36.7	7.0	0.3																																											
CL14-30	Ø54.9	Ø45.7	7.0	0.3																																											
CL14-45	Ø74.0	Ø62.7	7.0	0.3																																											
CL14-15	CL14-22	CL14-30	CL14-45																																												
515-0, 515-4 and 515-6 (pages 16 & 17)	522-0, 522-4 and 522-6 (pages 16 & 17)	530-0, 530-4 and 530-6 (pages 16 & 17)	545-0, 545-4 and 545-6 (pages 16 & 17)																																												
7104 (pages 22 & 23)	800-22, 810-22 (pages 18 & 19)	800-30, 805-30, 806-30 807-30 and 810-30 (pages 18 & 19)	800-45, 805-45 and 810-45 (pages 18 & 19)																																												
810-15 (pages 18 & 19)		1017, 1018, 1507 and 1509 (pages 26 & 27)																																													
		7124 (pages 22 & 23)																																													
CL15	 <p>Material: Carbon Spring Steel and Stainless Steel Spring Steel Finish: Self Colour</p>	<p>CL15 CLIP TO BE USED WITH THE FOLLOWING BALL UNITS</p> <table border="1"> <tbody> <tr> <td>1004 (pages 8 & 9)</td> <td>7104, 7124, 7125 7152 and 7171 (pages 22 & 23)</td> <td>0519-22, 3019-22, 1019-22 1029-22 and 2019-22 (pages 28 & 29)</td> </tr> <tr> <td>810-15, 800-22, 810-22 800-30, 805-30, 810-30 800-45, 805-45, 810-45 and 800-60 (pages 18 and 19)</td> <td>3010, 3011, 1017, 1018 1509, 1507, 1027, 1028 2009, 2010, 4007 and 4008 (pages 26 and 27)</td> <td></td> </tr> </tbody> </table> <p>Ball units with circlip grooves are available on request CL15 fixing clip sizes available upon request</p>	1004 (pages 8 & 9)	7104, 7124, 7125 7152 and 7171 (pages 22 & 23)	0519-22, 3019-22, 1019-22 1029-22 and 2019-22 (pages 28 & 29)	810-15, 800-22, 810-22 800-30, 805-30, 810-30 800-45, 805-45, 810-45 and 800-60 (pages 18 and 19)	3010, 3011, 1017, 1018 1509, 1507, 1027, 1028 2009, 2010, 4007 and 4008 (pages 26 and 27)																																								
		1004 (pages 8 & 9)	7104, 7124, 7125 7152 and 7171 (pages 22 & 23)	0519-22, 3019-22, 1019-22 1029-22 and 2019-22 (pages 28 & 29)																																											
810-15, 800-22, 810-22 800-30, 805-30, 810-30 800-45, 805-45, 810-45 and 800-60 (pages 18 and 19)	3010, 3011, 1017, 1018 1509, 1507, 1027, 1028 2009, 2010, 4007 and 4008 (pages 26 and 27)																																														

To order, specify REF N° i.e. CL11-22.
For CL12 and CL15 clips specify REF N° and ball unit REF N° i.e. CL12,1007.