

Tuli
www.tuli.si

TOPBALL®

TOPBALL

TOPBALL®

The NB TOPBALL is a linear motion mechanism utilizing the rotational motion of ball elements. NB's self-aligning TOPBALL can be designed into many different applications such as factory automated equipment, machine tools, industrial machines, electrical equipment, optical and measuring instruments.

STRUCTURE AND ADVANTAGES

Higher Load Capacity and Longer Travel life

NB's uniquely designed load plate provides circular arch contact to the ball element resulting in a greater dispersion of the load, enabling TOPBALL to provide up to three times the load capacity therefore 27 times the travel life of conventional slide bushings.

Self Aligning Capability

Load plates are thinner at the ends to provide a pivot point at the center of the plate. The center acts as a fulcrum to compensate for any slight misalignment between the shaft and the housing bore that might be caused by inaccurate machining, mounting errors or shaft deflection.

Straight load plate ST option is available for non self-alignment.

Floating Seal

NB's unique floating seal design allows for self-alignment while maintaining equal and constant contact to the shaft. Seals do not add to the overall length of the bushing allowing for more compact designs.

High Speed

TOPBALL meets high speed requirements. The maximum speed is 180m/min.

Clearance Adjustable

TOPBALL load plates are designed to "float" in the outer sleeve which allows for clearance between the ball elements and shaft to best suit application requirements.

TOPBALL Unit

This is a TOPBALL with a housing. The housing has the most appropriate bore tolerance that optimizes TOPBALL's performance.

Figure D-1 Circular Arch Design and Ground Surface Raceway

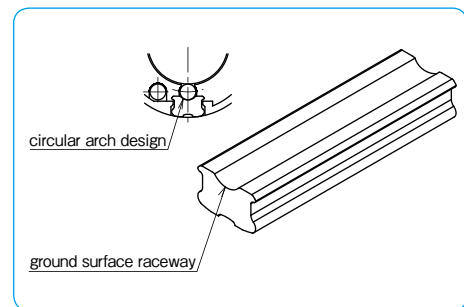
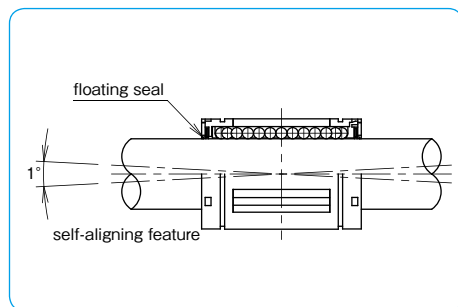

















Figure D-2 Floating Seal and Self-aligning Feature



TYPES

Table D-1 Types

		Metric Series		Inch Series	
TOPBALL	closed type	TK  P.D-6	TW  P.D-8		
	open type	TK-OP  P.D-6	TW-OP  P.D-8		
TOPBALL Unit	closed type	TKA  P.D-10	TKA-W  P.D-11	TWA  P.D-16	TWA-W  P.D-17
	adjustable type	/		TWJ  P.D-18	TWJ-W  P.D-19
	open type	TKE  P.D-12	TKE-W  P.D-13	/	
	adjustable-open type	TKD  P.D-14	TKD-W  P.D-15	TWD  P.D-20	TWD-W  P.D-21

LIFE CALCULATION

Since ball elements are used as the rolling element in the NB TOPBALL, the following equation is used to calculate the rated life.

$$L = \left(\frac{f_H \cdot f_T \cdot f_C \cdot C}{f_W \cdot P} \right)^3 \cdot 50$$

L: rated life (km) f_H: hardness coefficient
 f_T: temperature coefficient f_C: contact coefficient
 f_W: applied load coefficient (Table D-2)
 C: basic dynamic load rating (N) P: applied load (N)
 *Refer to page Eng-5 for the coefficients.

Applied Load Coefficient (f_w)

When calculating the applied load, the weight of the mass, inertial force, moment resulting from the motion, and the variation with time should be accurately estimated. However, it is very difficult to accurately estimate the applied load due to the existence of numerous variables, including the start/stop conditions of the reciprocating motion and of the shock/vibration. Estimation is simplified by using the values given in Table D-2.

If the stroke and number of cycles per unit time are constant, the life time is calculated using the following equation.

$$L_h = \frac{L \cdot 10^3}{2 \cdot \ell_s \cdot n \cdot 60}$$

L_h: life time (hr) ℓ_s: stroke length (m)
 L: rated life (km) n: number of cycles per minute (cpm)

Table D-2 Applied Load Coefficient

operating conditions	applied load coefficient f _w
no shock/vibration 15 m/min or less	1.0~1.5
low shock/vibration 60 m/min or less	1.5~2.0
high shock/vibration 90 m/min or less	2.0~3.5
high shock/vibration 180 m/min or less	3.5 or more

Relation Between Ball Circuits and Load Rating

The load rating varies according to the loaded position on the circumference. The value in the dimension table indicates the lowest load rating with the load placed on top of one ball circuit. Table D-3 shows the load ratio for the TK and TW TOPBALL.

Table D-3 Load Positions

size	TK8	TK10~TK16	TK20~TK50	TW3~TW8	TW10	TW12~TW32
C (dynamic load rating in the table)						
C _{max} (maximum dynamic load rating)						
load ratio C _{max} /C C _{MAX} /C	1.414	1.463	1.280	1.414	1.463	1.280
C _z (dynamic load rating in reverse direction)	none					
load ratio C _z /C C _z /C	—	0.44 (except for TK10)	0.60	0.70 (TW8 only)	0.44	0.57

MOUNTING

Clearance and Fit

An appropriate clearance between TOPBALL and shaft is required in TOPBALL operation. Inadequate clearance may cause early failure and/or poor, rough movement. Proper clearance is determined by shaft diameter and housing bore. Table D-4 and D-5 show recommended tolerances of the shaft and housing bore.

Shaft and Housing

To optimize NB TOPBALL performance, high precision shafts and housings are required.

1. Shaft: Dimensional tolerance, surface roughness and hardness greatly affect the traveling performance of the TOPBALL.

The shaft must be manufactured to the following tolerances.

- A. Surface roughness of Ra0.4 or less.
- B. Hardness of 60 HRC or more (refer to page Eng-5).
- C. The proper tolerance of the shaft diameter is recommended on Table D-4 and D-5.

The NB Shaft is an ideal component manufactured to meet these specifications. Please see pages F-1 ~ for details.

2. Housing: There are a wide range of designs and manufacturing techniques for housings. NB TOPBALL Units are available as standard products. When housings are prepared separately please refer to Table D-4 and D-5 for a proper fit.

Table D-4: Recommended Tolerance for Shaft Dia. and Housing Bore

part number	shaft dia.		housing bore	
	dr mm	tol. (h6) μm	D mm	tol. (H7) μm
TK 8	8	0	16	+18/0
TK10	10	-9	19	+21 0
TK12	12	0	22	
TK16	16	-11	26	+25 0
TK20	20	0	32	
TK25	25	0	40	+30 0
TK30	30	-13	47	
TK40	40	0	62	0
TK50	50	-16	75	

Table D-5: Recommended Tolerance for Shaft Dia. and Housing Bore

part number	shaft dia.		housing bore	
	dr inch	tol. (g6) inch	D inch	tol. (H7) inch
TW 3	.1875	-.0002	.3750	+0.005/0
TW 4	.2500	-.0006	.5000	+0.007 0
TW 6	.3750	-.0006	.6250	0
TW 8	.5000	-.0002	.8750	+0.008
TW10	.6250	-.0007	1.1250	0
TW12	.7500	-.0003	1.2500	+0.010
TW16	1.0000	-.0008	1.5625	0
TW20	1.2500	-.0004	2.0000	+0.012 0
TW24	1.5000	-.0010	2.3750	
TW32	2.0000	-.0004/-0.0012	3.0000	0

Mounting

TK type TOPBALL is designed to be press fitted into the housing bore. When inserting bushing, however, don't apply excess force nor shock load which may cause permanent damage. For TW type TOPBALL, examples of mouting are shown in Figures D-3~6 and D-8.

Examples of Mounting

Figures D-3 to D-8 illustrate mounting methods as example.

Figure D-3 Use of Holding Plates

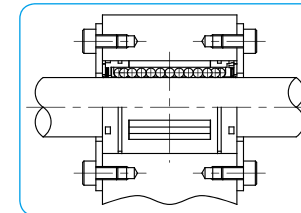

Figure D-4 Clearance Adjustable Type

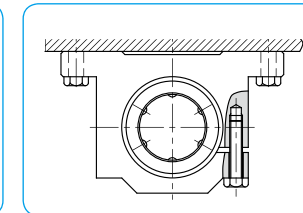

Figure D-5 Use of Retaining Rings

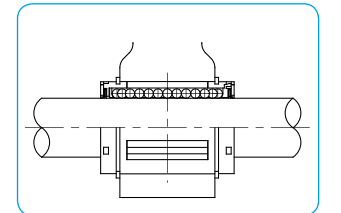

Figure D-6 Open Type

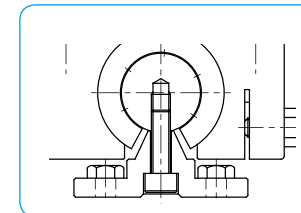

Figure D-7 Press Fit (TK type)

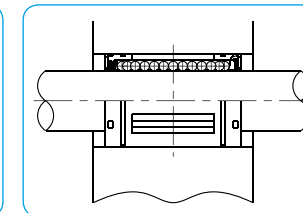
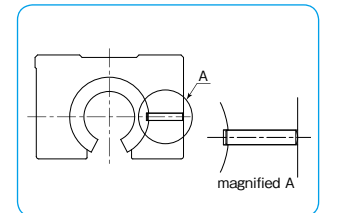

Figure D-8 Pin Fixing



* Please contact NB for SA type support rails' compatibility with the TOPBALL units.

* Please fix by the pin for open type housing .

SPECIFICATION

Anti-Corrosive Type

A special TOPBALL is also available for anti-corrosive requirements. Please specify with a suffix "-SK" for either TOPBALL or TOPBALL Unit part number. The load plates are electroless nickel plated and balls are made of stainless steel.

TK TYPE

– TOPBALL Metric Type –



part number structure

example **TK 20 UU-OP-ST-SK**

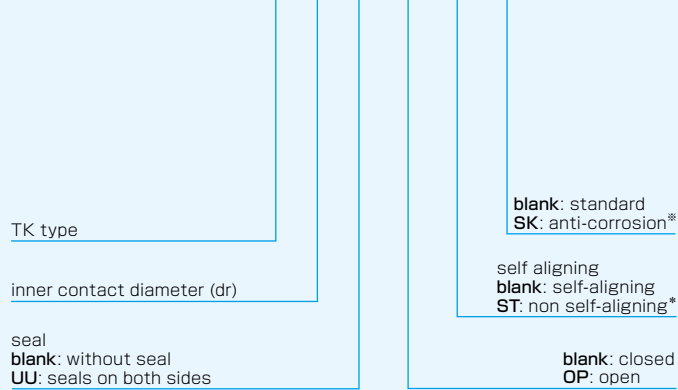

※For anti-corrosion the load plates are electroless nickel plated with stainless steel balls.
*ST option is available for size 12 to 40

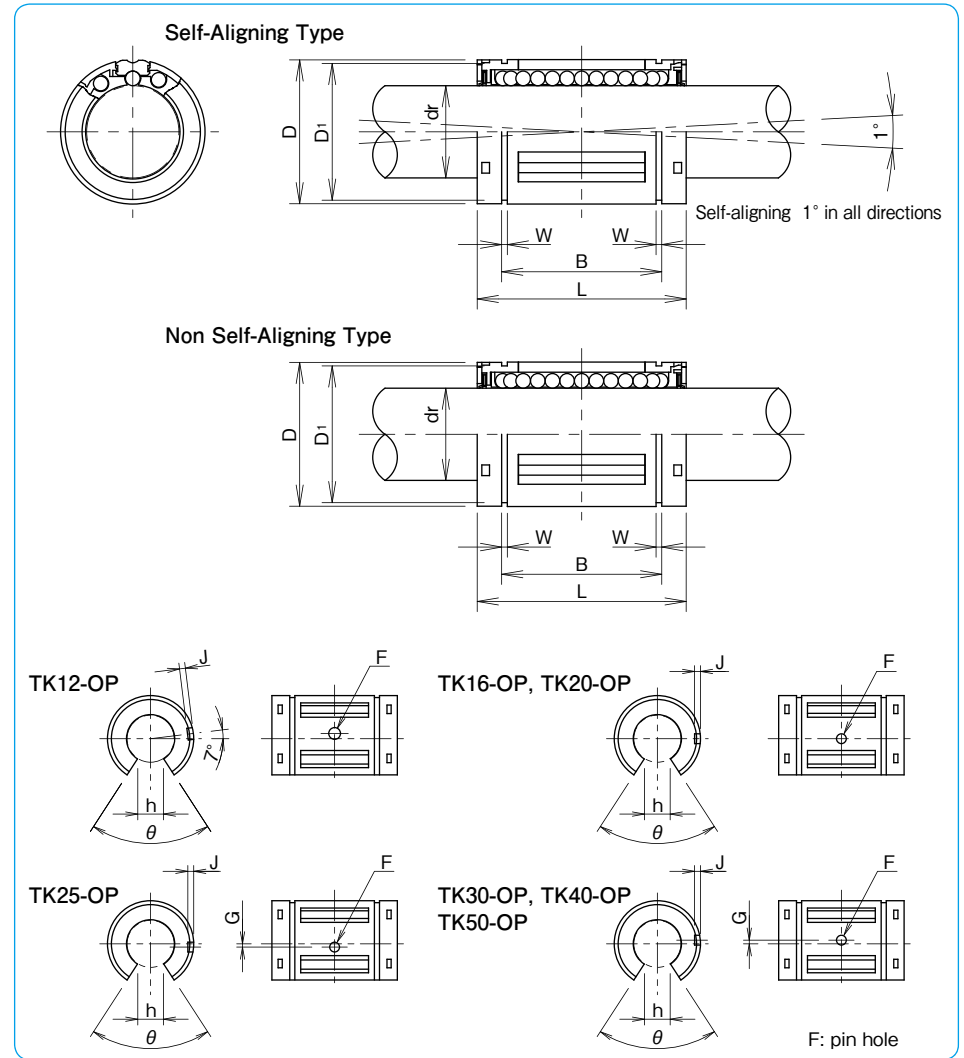

closed type		part number		open type		major dimensions				
number of ball circuits	mass g		number of ball circuits	mass g	mm	dr* tolerance μm	D mm	L mm	tolerance mm	
TK 8	4	7.3	—	—	8	+ 8	16	25	±0.2	
TK10	5	14	—	—	10		19	29		
TK12	5	21	TK12-OP	4	17	0	22	32		
TK16	5	43	TK16-OP	4	35	+ 9	26	36		
TK20	6	58	TK20-OP	5	48	- 1	32	45		
TK25	6	123	TK25-OP	5	103	+11	40	58		
TK30	6	216	TK30-OP	5	177	- 1	47	68		
TK40	6	333	TK40-OP	5	275	+13	62	80		
TK50	6	618	TK50-OP	5	520	-2	75	100		

One-sided seal is also available. Please contact NB for details.

* Based on nominal housing bore

mm	B tolerance mm	W mm	D ₁ mm	h mm	θ	open type			basic load rating dynamic C N	static Co N	shaft diameter mm
						F ^{H11} mm	G mm	J mm			
16.5	-0.2	1.1	15.2	—	—	3	—	—	423	534	8
22.0		1.3	18	—	—		—	—	750	935	10
22.9		1.3	21	6.5	66°		—	0.7	1,020	1,290	12
24.9		1.3	24.9	9	68°		—	1.0	1,250	1,550	16
31.5	0	1.6	30.3	9	55°		—	1.0	2,090	2,630	20
44.1		1.85	37.5	11.5	57°		1.5	1.5	3,780	4,720	25
52.1		1.85	44.5	14	57°		2	1.7	5,470	6,810	30
60.6		-0.3	2.15	59	19.5		56°	1.5	2.4	6,590	8,230
77.6	2.65		72	22.5	54°		5	2.5	2.7	10,800	13,500

1N≒0.102kgf

TW TYPE

– TOPBALL Inch Type –

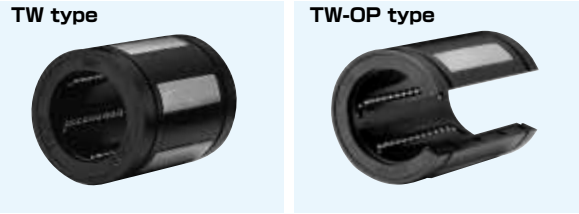

part number structure

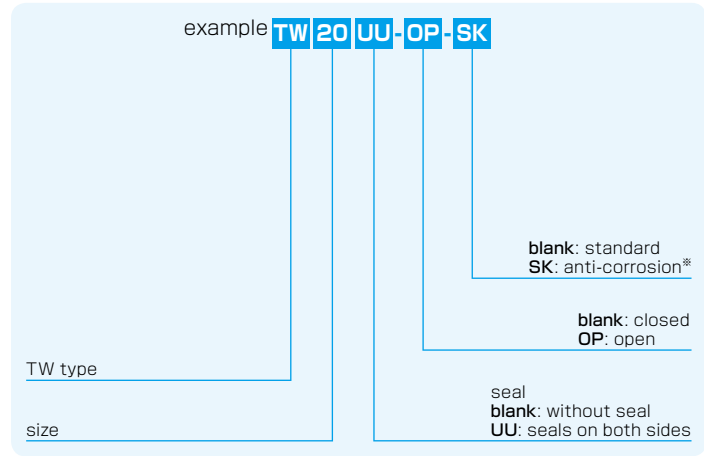

*For anti-corrosion the load plates are electroless nickel plated with stainless steel balls.

part number						major dimensions					
closed type			open type			dr*	D				
number of ball circuits	mass lbs		number of ball circuits	mass lbs	inch		tolerance inch	inch	inch	tolerance inch	
TW 3	4	.004	—	—	—	0	-0.005	.3750	.562	±.008	
TW 4	4	.009	—	—	—			.2500	.750	0	
TW 6	4	.014	—	—	—			.3750	.875	-.015	
TW 8	4	.043	TW 8-OP	3	.033			.5000	1.1250	1.250	0
TW 10	5	.103	TW 10-OP	4	.083			.6250	1.2500	1.625	0
TW 12	6	.123	TW 12-OP	5	.102	.7500	1.2500	1.625	-.020		
TW 16	6	.265	TW 16-OP	5	.220	1.0000	1.5625	2.250			
TW 20	6	.485	TW 20-OP	5	.419	1.2500	2.0000	2.625	0/- .025		
TW 24	6	.750	TW 24-OP	5	.639	1.5000	2.3750	3.000	0/- .030		
TW 32	6	1.411	TW 32-OP	5	1.168	2.0000	3.0000	4.000	0/- .040		

* Based on nominal housing bore

** Seals are not available on TW3.

*** One-sided seal is also available. Please contact NB for details.

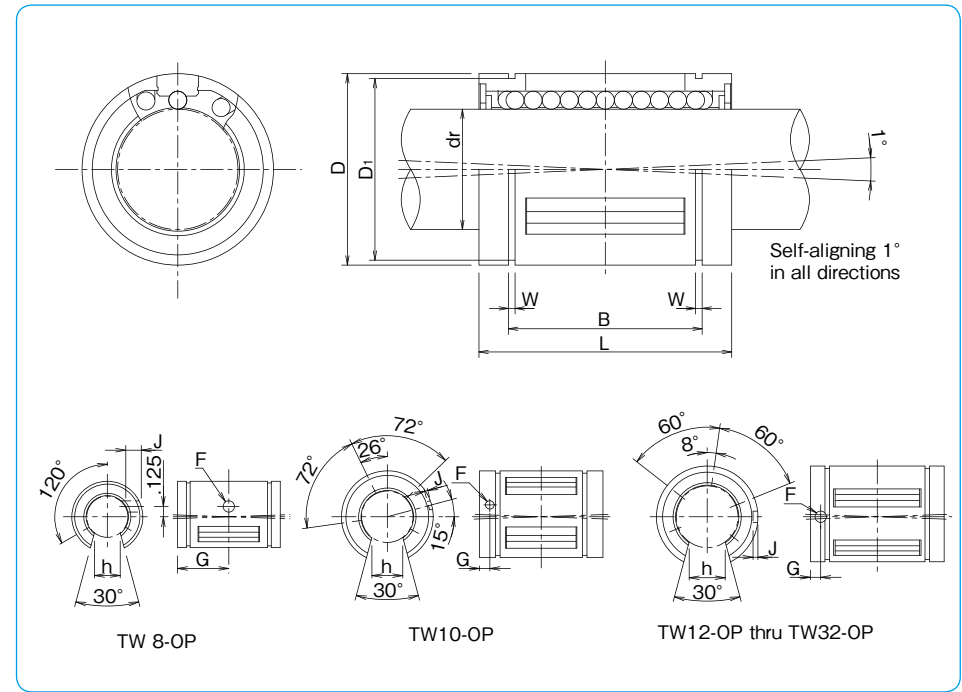

inch	B tolerance inch	W inch	D ₁ inch	h inch	open type			basic load rating dynamic C lbf	static Co lbf	nominal shaft diameter inch
					F inch	G inch	J inch			
—	—	—	—	—	—	—	—	35	47	3/16
.515	0	.0390	.4687	—	—	—	—	60	80	1/4
.703	-.015	.0390	.5880	—	—	—	—	95	120	3/8
1.032	0	.0459	.8209	.313	.136	.6250	through	230	290	1/2
1.112		.0559	1.0590	.375	.105	.1250	.0390	400	500	5/8
1.272		.0559	1.1760	.438	.136	.1250	.0590	470	590	3/4
1.886		.0679	1.4687	.563	.136	.1250	.0470	850	1,060	1
2.011		0/- .025	.0679	1.8859	.625	.201	.1875	.0900	1,230	1,530
2.422	0/- .030	.0859	2.2389	.750	.201	.1875	.0900	1,480	1,850	1-1/2
3.206	0/- .040	.1029	2.8379	1.000	.265	.3125	through	2,430	3,040	2

1inch=25.4mm

1lbs≐0.454kg

1lbf≐4.448N

TKA TYPE (Euro Standard)

– Block Type –

part number structure

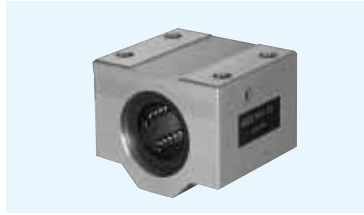
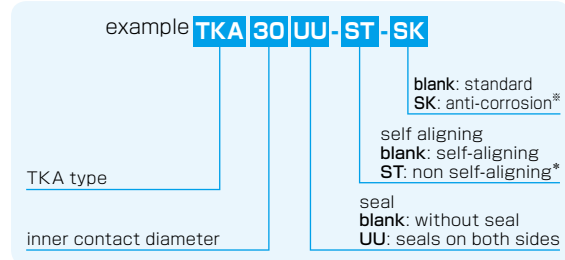

*For anti-corrosion the load plates are electroless nickel plated with stainless steel balls.
*ST option is available for size 12 to 40

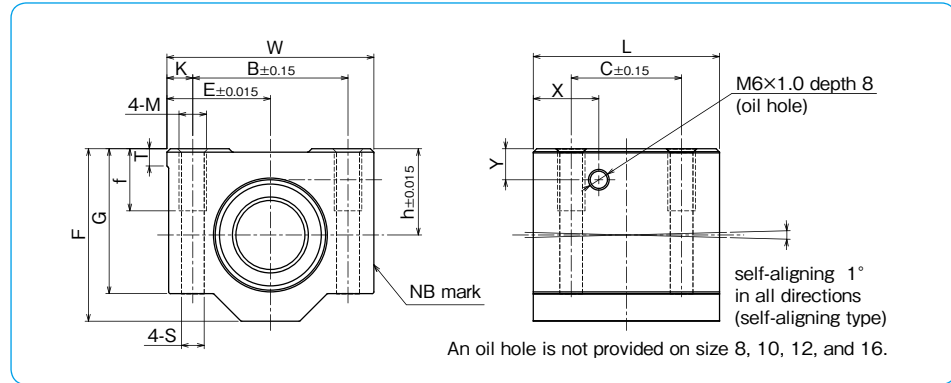

part number	inner contact diameter mm	major dimensions									mounting dimensions						basic load rating		mass g
		h	E	W	L	F	G	T	X	Y	B	C	K	M	f	S	dynamic C N	static Co N	
TKA 8UU	8	15	17.5	35	32	28	22	5	—	—	25	20	5	M4	9	3.3	423	534	59
TKA 10UU	10	16	20	40	36	31.5	25	5	—	—	29	20	5.5	M5	11	4.3	750	935	90
TKA 12UU	12	18	21.5	43	39	35	28	5	—	—	32	23	5.5	M5	11	4.3	1,020	1,290	116
TKA 16UU	16	22	26.5	53	43	42	35	5	—	—	40	26	6.5	M6	13	5.3	1,250	1,550	205
TKA 20UU	20	25	30	60	54	50	42	5	19	9	45	32	7.5	M8	18	6.6	2,090	2,630	326
TKA 25UU	25	30	39	78	67	60	48	7	22.5	10	60	40	9	M10	22	8.4	3,780	4,720	624
TKA 30UU	30	35	43.5	87	79	70	58	8	26	11.5	68	45	9.5	M10	22	8.4	5,470	6,810	980
TKA 40UU	40	45	54	108	91	90	72	10	26.5	14	86	58	11	M12	26	10.5	6,590	8,230	1,670

1N≐0.102kgf

TKA-W TYPE (Euro Standard)

– Double-Wide Block Type –

part number structure

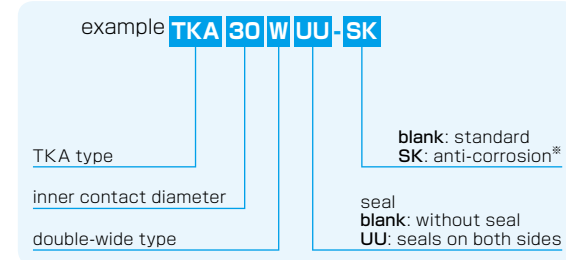

*For anti-corrosion the load plates are electroless nickel plated with stainless steel balls.

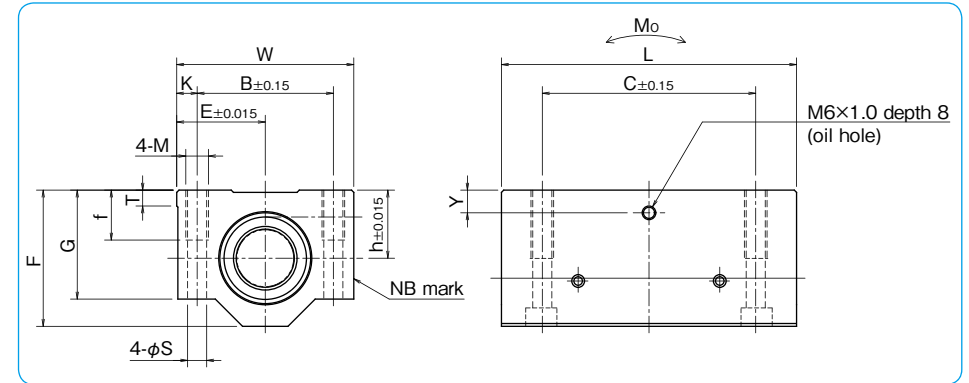

part number	inner contact diameter mm	major dimensions									mounting dimensions						basic load rating		allowable static moment		mass g
		h	E	W	L	F	G	T	Y	B	C	K	M	f	S	dynamic C N	static Co N	Mo N·m	g		
TKA 8WUU	8	15	17.5	35	62	28	22	5	6.5	25	50	5	M4	9	3.3	685	1,068	6.53	119		
TKA 10WUU	10	16	20	40	70	31.5	25	5	7	29	52	5.5	M5	11	4.3	1,215	1,870	13.4	175		
TKA 12WUU	12	18	21.5	43	76	35	28	5	7.5	32	56	5.5	M5	11	4.3	1,652	2,580	20.9	227		
TKA 16WUU	16	22	26.5	53	84	42	35	5	9.5	40	64	6.5	M6	13	5.3	2,025	3,100	28.2	390		
TKA 20WUU	20	25	30	60	104	50	42	5	9	45	76	7.5	M8	18	6.6	3,390	5,260	62.0	630		
TKA 25WUU	25	30	39	78	130	60	48	7	10	60	94	9	M10	22	8.4	6,120	9,440	149	1,210		
TKA 30WUU	30	35	43.5	87	152	70	58	8	11.5	68	106	9.5	M10	22	8.4	8,860	13,620	247	1,880		
TKA 40WUU	40	45	54	108	176	90	72	10	14	86	124	11	M12	26	10.5	10,680	16,460	349	3,280		

1N≐0.102kgf

TKE TYPE (Euro Standard)

– Open Block Type –



part number structure

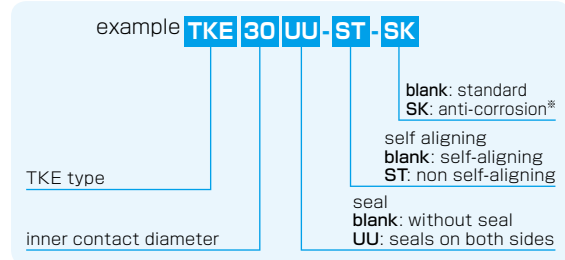

※For anti-corrosion the load plates are electroless nickel plated with stainless steel balls.

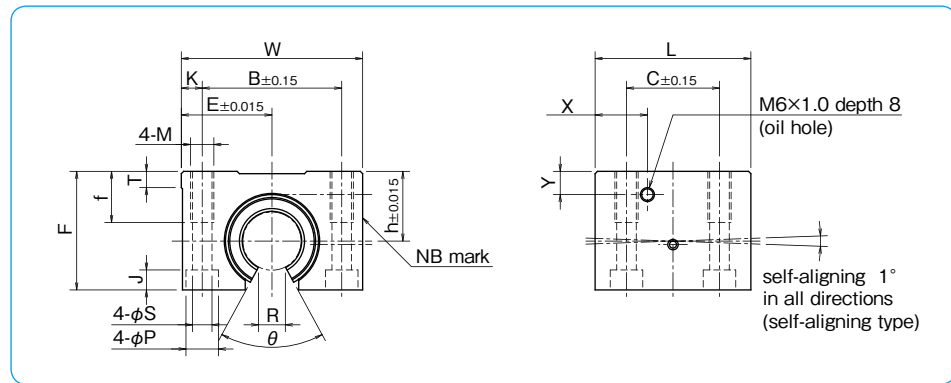

part number	inner contact diameter	major dimensions										mounting dimensions										basic load rating			mass
		h	E	W	L	F	T	R	θ	X	Y	B	C	K	M	f	S	P	J	dynamic C	static Co	mass N			
TKE12UU	12	18	21.5	43	39	28	5	6.5	66°	14.5	7.5	32	23	5.5	M5	11	4.3	8	4.5	1,020	1,290	99			
TKE16UU	16	22	26.5	53	43	35	5	9	68°	15.5	9.5	40	26	6.5	M6	13	5.3	9.5	5.5	1,250	1,550	175			
TKE20UU	20	25	30	60	54	42	5	9	55°	19	9	45	32	7.5	M8	18	6.6	11	6.5	2,090	2,630	275			
TKE25UU	25	30	39	78	67	51	7	11.5	57°	22.5	10	60	40	9	M10	22	8.4	14	8.6	3,780	4,720	558			
TKE30UU	30	35	43.5	87	79	60	8	14	57°	26	11.5	68	45	9.5	M10	22	8.4	14	8.6	5,470	6,810	860			
TKE40UU	40	45	54	108	91	77	10	19.5	56°	26.5	14	86	58	11	M12	26	10.5	17.5	10.8	6,590	8,230	1,490			

1N≐0.102kgf

TKE-W TYPE (Euro Standard)

– Double-Wide Open Block Type –



part number structure

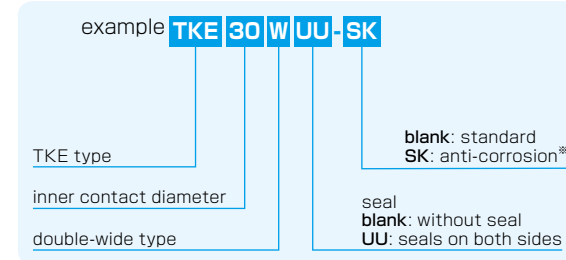

※For anti-corrosion the load plates are electroless nickel plated with stainless steel balls.

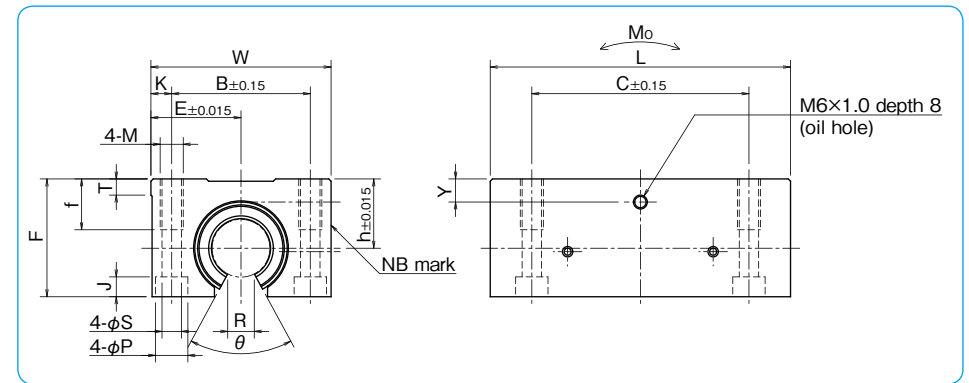

part number	inner contact diameter	major dimensions										mounting dimensions										basic load rating			allowable static moment		mass
		h	E	W	L	F	T	R	θ	Y	B	C	K	M	f	S	P	J	dynamic C	static Co	mass N	Mo N·m	g				
TKE12WUU	12	18	21.5	43	76	28	5	6.5	66°	7.5	32	56	5.5	M5	11	4.3	8	4.5	1,652	2,580	11.3	190					
TKE16WUU	16	22	26.5	53	84	35	5	9	68°	9.5	40	64	6.5	M6	13	5.3	9.5	5.5	2,025	3,100	15.2	312					
TKE20WUU	20	25	30	60	104	42	5	9	55°	9	45	76	7.5	M8	18	6.6	11	6.5	3,390	5,260	35.3	505					
TKE25WUU	25	30	39	78	130	51	7	11.5	57°	10	60	94	9	M10	22	8.4	14	8.6	6,120	9,440	85.2	1,050					
TKE30WUU	30	35	43.5	87	152	60	8	14	57°	11.5	68	106	9.5	M10	22	8.4	14	8.6	8,860	13,620	140	1,630					
TKE40WUU	40	45	54	108	176	77	10	19.5	56°	14	86	124	11	M12	26	10.5	17.5	10.8	10,680	16,460	199	2,880					

1N≐0.102kgf

TKD TYPE (Euro Standard)

– Clearance Adjustable Open Block Type –

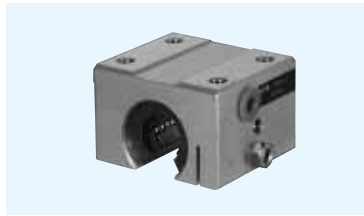

part number structure

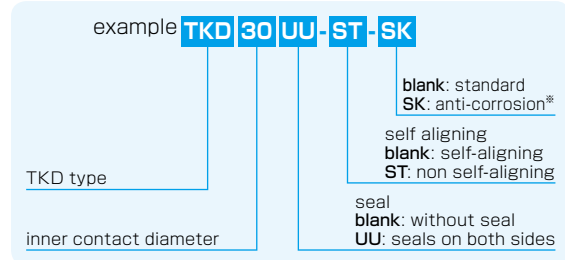

※For anti-corrosion the load plates are electroless nickel plated with stainless steel balls.

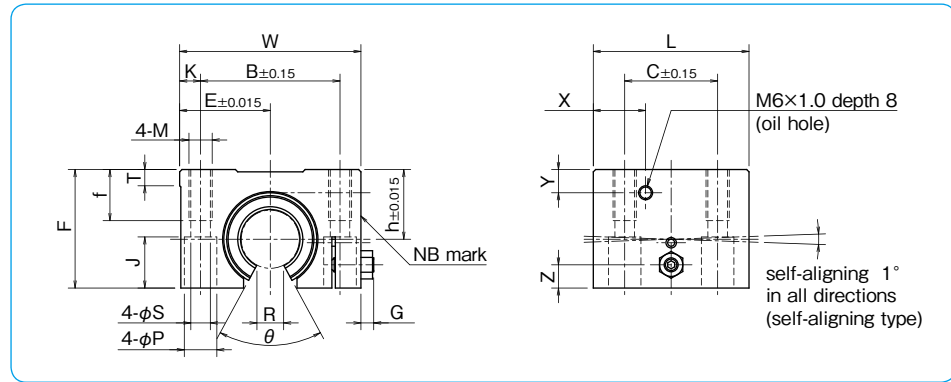

part number	inner contact diameter	major dimensions										mounting dimensions										basic load rating			allowable static moment	mass
		h	E	W	L	F	G	Z	T	R	θ	X	Y	B	C	K	M	f	S	P	J	dynamic C	static Co	mass N		
TKD12UU	12	18	21.5	43	39	28	3.2	5	5	6.5	66°	14.5	7.5	32	23	5.5	M5	11	4.3	8	11.5	1,020	1,290	99		
TKD16UU	16	22	26.5	53	43	35	3.2	6	5	9	68°	15.5	9.5	40	26	6.5	M6	13	5.3	9.5	14	1,250	1,550	175		
TKD20UU	20	25	30	60	54	42	4	8	5	9	55°	19	9	45	32	7.5	M8	18	6.6	11	18	2,090	2,630	275		
TKD25UU	25	30	39	78	67	51	5.5	10	7	11.5	57°	22.5	10	60	40	9	M10	22	8.4	14	22	3,780	4,720	558		
TKD30UU	30	35	43.5	87	79	60	5.5	12	8	14	57°	26	11.5	68	45	9.5	M10	22	8.4	14	26	5,470	6,810	860		
TKD40UU	40	45	54	108	91	77	5	15	10	19.5	56°	26.5	14	86	58	11	M12	26	10.5	17.5	33	6,590	8,230	1,490		

1N≒0.102kgf

TKD-W TYPE (Euro Standard)

– Clearance Adjustable Double-Wide Open Block Type –



part number structure

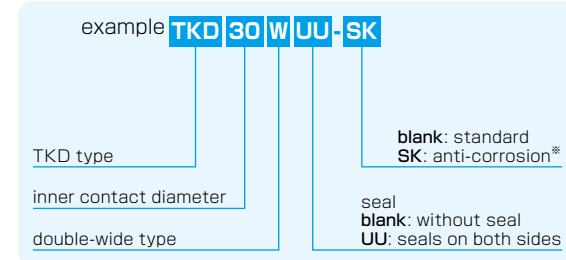

※For anti-corrosion the load plates are electroless nickel plated with stainless steel balls.

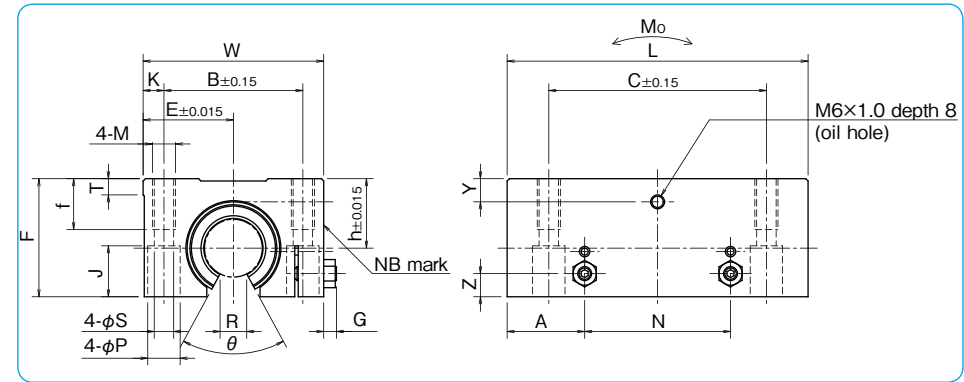

part number	inner contact diameter	major dimensions										mounting dimensions										basic load rating			allowable static moment	mass
		h	E	W	L	F	G	Z	A	N	T	R	θ	Y	B	C	K	M	f	S	P	J	dynamic C	static Co		
TKD12WUU	12	18	21.5	43	76	28	3.2	5	19.5	37	5	6.5	66°	7.5	32	5.5	M5	11	4.3	8	11.5	1,652	2,580	11.3	190	
TKD16WUU	16	22	26.5	53	84	35	3.2	6	21.5	41	5	9	68°	9.5	40	6.5	M6	13	5.3	9.5	14	2,025	3,100	15.2	312	
TKD20WUU	20	25	30	60	104	42	4	8	27	50	5	9	55°	9	45	7.5	M8	18	6.6	11	18	3,390	5,260	35.3	505	
TKD25WUU	25	30	39	78	130	51	5.5	10	33.5	63	7	11.5	57°	10	60	9.5	M10	22	8.4	14	22	6,120	9,440	85.2	1,050	
TKD30WUU	30	35	43.5	87	152	60	5.5	12	39.5	73	8	14	57°	11.5	68	10.5	M10	22	8.4	14	26	8,860	13,620	140	1,630	
TKD40WUU	40	45	54	108	176	77	5	15	45.5	85	10	19.5	56°	14	86	12.5	M12	26	10.5	17.5	33	10,680	16,460	199	2,880	

1N≒0.102kgf

TWA TYPE (Inch Standard)

– Block Type –

part number structure

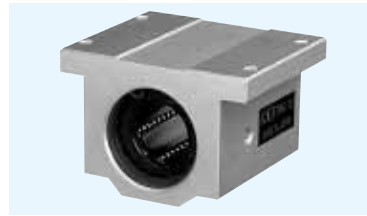
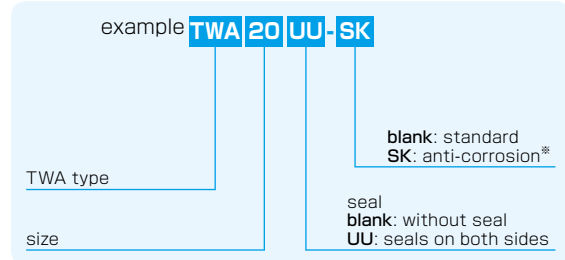

※For anti-corrosion the load plates are electroless nickel plated with stainless steel balls.

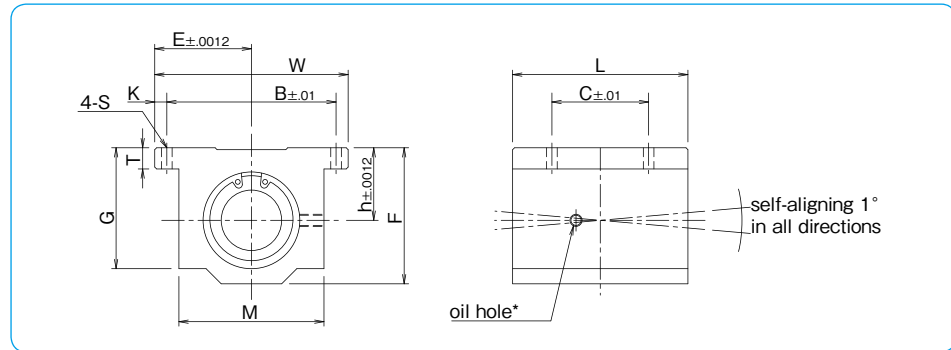

part number	nom. shaft dia.	major dimensions								mounting dimensions				basic load rating		mass
		h	E	W	L	F	T	G	M	B	C	K	S	dynamic C	static Co	
TWA 4UU	1/4	.4370	.8125	1.625	1.188	.813	.188	.750	1.000	1.312	.750	.156	.156	60	80	.090
TWA 6UU	3/8	.5000	.8750	1.750	1.313	.938	.188	.875	1.125	1.437	.875	.156	.156	95	120	.120
TWA 8UU	1/2	.6870	1.0000	2.000	1.688	1.250	.250	1.125	1.375	1.688	1.000	.156	.156	230	290	.248
TWA 10UU	5/8	.8750	1.2500	2.500	1.938	1.625	.281	1.437	1.750	2.125	1.125	.188	.188	400	500	.465
TWA 12UU	3/4	.9370	1.3750	2.750	2.063	1.750	.313	1.563	1.875	2.375	1.250	.188	.188	470	590	.553
TWA 16UU	1	1.1870	1.6250	3.250	2.813	2.188	.375	1.938	2.375	2.875	1.750	.188	.219	850	1060	1.200
TWA 20UU	1-1/4	1.5000	2.0000	4.000	3.625	2.813	.438	2.500	3.000	3.500	2.000	.250	.219	1230	1530	2.380
TWA 24UU	1-1/2	1.7500	2.3750	4.750	4.000	3.250	.500	2.875	3.500	4.125	2.500	.313	.281	1480	1850	3.460
TWA 32UU	2	2.1250	3.0000	6.000	5.000	4.063	.625	3.625	4.500	5.250	3.250	.375	.406	2430	3040	6.830

* Provided with push-in oil fitting for 1/4" to 1/2" sizes. Sizes from 5/8" to 2" offer a 1/4-28 tapped hole with a plug for adding a fitting if desired.

1inch=25.4mm
1lbs≐0.454kg
1lbf≐4.448N

TWA-W TYPE (Inch Standard)

– Double-Wide Block Type –

part number structure

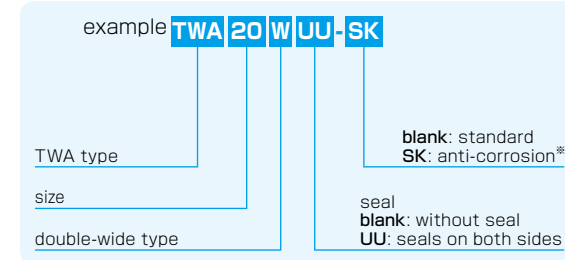

※For anti-corrosion the load plates are electroless nickel plated with stainless steel balls.

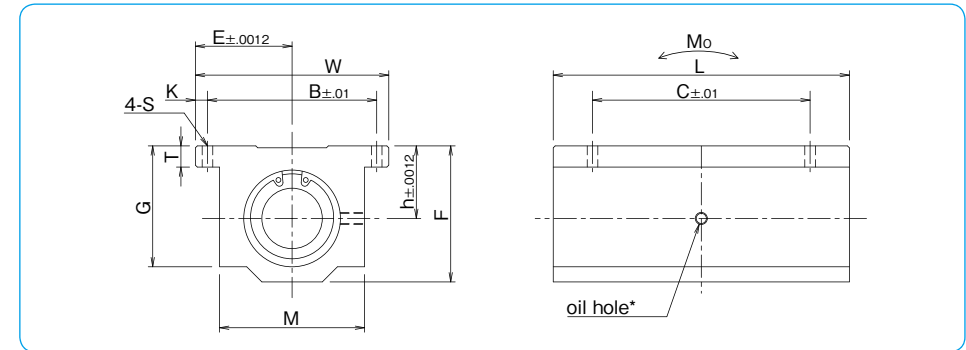

part number	nom. shaft dia.	major dimensions								mounting dimensions				basic load rating		allowable static moment	mass
		h	E	W	L	F	T	G	M	B	C	K	S	dynamic C	static Co	Mo	
TWA 4WUU	1/4	.4370	.8125	1.625	2.500	.813	.188	.750	1.000	1.312	2.000	.156	.156	96	160	26.8	.190
TWA 6WUU	3/8	.5000	.8750	1.750	2.750	.938	.188	.875	1.125	1.437	2.250	.156	.156	150	240	52.2	.250
TWA 8WUU	1/2	.6870	1.0000	2.000	3.500	1.250	.250	1.125	1.375	1.688	2.500	.156	.156	370	580	183	.510
TWA 10WUU	5/8	.8750	1.2500	2.500	4.000	1.625	.281	1.437	1.750	2.125	3.000	.188	.188	640	1000	373	1.000
TWA 12WUU	3/4	.9370	1.3750	2.750	4.500	1.750	.313	1.563	1.875	2.375	3.500	.188	.188	750	1180	496	1.200
TWA 16WUU	1	1.1870	1.6250	3.250	6.000	2.188	.375	1.938	2.375	2.875	4.500	.188	.219	1360	2120	1260	2.400
TWA 20WUU	1-1/4	1.5000	2.0000	4.000	7.500	2.813	.438	2.500	3.000	3.500	5.500	.250	.219	1970	3060	2100	5.000
TWA 24WUU	1-1/2	1.7500	2.3750	4.750	9.000	3.250	.500	2.875	3.500	4.125	6.500	.313	.281	2370	3700	2900	7.800

* Provided with push-in oil fitting for 1/4" to 1/2" sizes. Sizes from 5/8" to 1-1/2" offer a 1/4-28 tapped hole with a plug for adding a fitting if desired.

1inch=25.4mm
1lbs≐0.454kg
1lbf≐4.448N
1lbf · in≐0.112N · m

TWJ TYPE (Inch Standard)

— Clearance Adjustable Block Type —

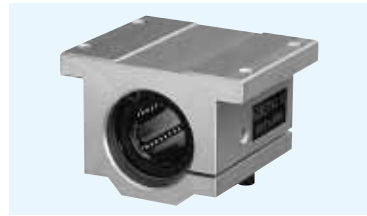

part number structure

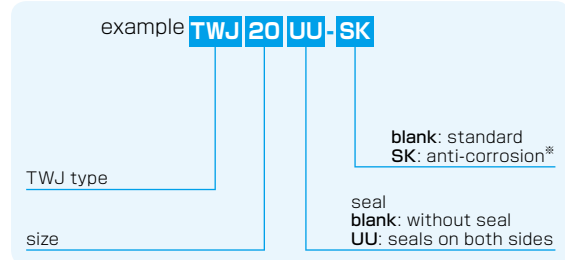

*For anti-corrosion the load plates are electroless nickel plated with stainless steel balls.

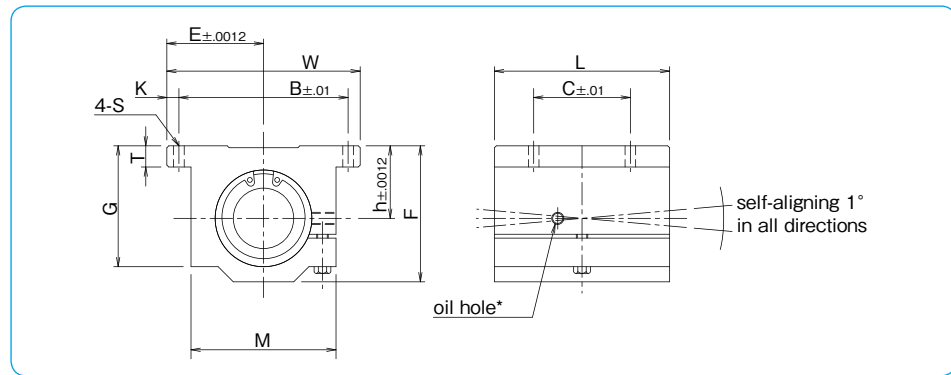

part number	nom. shaft dia. inch	major dimensions								mounting dimensions				basic load rating		mass lbs
		h	E	W	L	F	T	G	M	B	C	K	S	C lbf	Co lbf	
TWJ 4UU	1/4	.4370	.8125	1.625	1.188	.813	.188	.750	1.000	1.312	.750	.156	.156	60	80	.090
TWJ 6UU	3/8	.5000	.8750	1.750	1.313	.938	.188	.875	1.125	1.437	.875	.156	.156	95	120	.120
TWJ 8UU	1/2	.6870	1.0000	2.000	1.688	1.250	.250	1.125	1.375	1.688	1.000	.156	.156	230	290	.248
TWJ 10UU	5/8	.8750	1.2500	2.500	1.938	1.625	.281	1.437	1.750	2.125	1.125	.188	.188	400	500	.465
TWJ 12UU	3/4	.9370	1.3750	2.750	2.063	1.750	.313	1.563	1.875	2.375	1.250	.188	.188	470	590	.553
TWJ 16UU	1	1.1870	1.6250	3.250	2.813	2.188	.375	1.938	2.375	2.875	1.750	.188	.219	850	1060	1.200
TWJ 20UU	1-1/4	1.5000	2.0000	4.000	3.625	2.813	.438	2.500	3.000	3.500	2.000	.250	.219	1230	1530	2.380
TWJ 24UU	1-1/2	1.7500	2.3750	4.750	4.000	3.250	.500	2.875	3.500	4.125	2.500	.313	.281	1480	1850	3.460
TWJ 32UU	2	2.1250	3.0000	6.000	5.000	4.063	.625	3.625	4.500	5.250	3.250	.375	.406	2430	3040	6.830

* Provided with push-in oil fitting for 1/4" to 1/2" size. Sizes from 5/8" to 2" offer a 1/4-28 tapped hole with a plug for adding a fitting if desired.

1inch=25.4mm
1lbs≈0.454kg
1lbf=4.448N

TWJ-W TYPE (Inch Standard)

— Clearance Adjustable Double-Wide Block Type —



part number structure

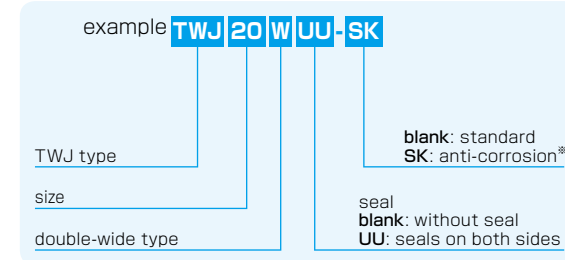

*For anti-corrosion the load plates are electroless nickel plated with stainless steel balls.

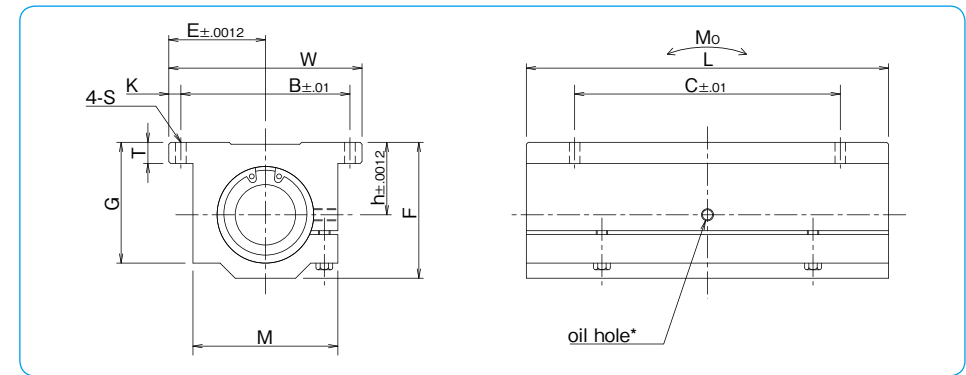

part number	nom. shaft dia. inch	major dimensions								mounting dimensions				basic load rating		allowable static moment	mass lbs
		h	E	W	L	F	T	G	M	B	C	K	S	C lbf	Co lbf	Mo lbf·in	
TWJ 4WUU	1/4	.4370	.8125	1.625	2.500	.813	.188	.750	1.000	1.312	2.000	.156	.156	96	160	26.8	.190
TWJ 6WUU	3/8	.5000	.8750	1.750	2.750	.938	.188	.875	1.125	1.437	2.250	.156	.156	150	240	52.2	.250
TWJ 8WUU	1/2	.6870	1.0000	2.000	3.500	1.250	.250	1.125	1.375	1.688	2.500	.156	.156	370	580	183	.510
TWJ 10WUU	5/8	.8750	1.2500	2.500	4.000	1.625	.281	1.437	1.750	2.125	3.000	.188	.188	640	1000	373	1.000
TWJ 12WUU	3/4	.9370	1.3750	2.750	4.500	1.750	.313	1.563	1.875	2.375	3.500	.188	.188	750	1180	496	1.200
TWJ 16WUU	1	1.1870	1.6250	3.250	6.000	2.188	.375	1.938	2.375	2.875	4.500	.188	.219	1360	2120	1260	2.400
TWJ 20WUU	1-1/4	1.5000	2.0000	4.000	7.500	2.813	.438	2.500	3.000	3.500	5.500	.250	.219	1970	3060	2100	5.000
TWJ 24WUU	1-1/2	1.7500	2.3750	4.750	9.000	3.250	.500	2.875	3.500	4.125	6.500	.313	.281	2370	3700	2900	7.800

* Provided with push-in oil fitting for 1/4" to 1/2" size. Sizes from 5/8" to 1-1/2" offer a 1/4-28 tapped hole with a plug for adding a fitting if desired.

1inch=25.4mm
1lbs≈0.454kg
1lbf=4.448N
1lbf·in≈0.112N·m

TWD TYPE (Inch Standard)

– Open Block Type –

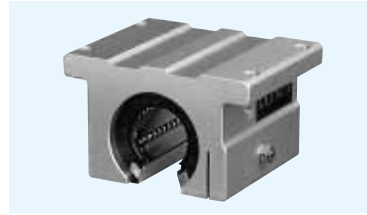

part number structure

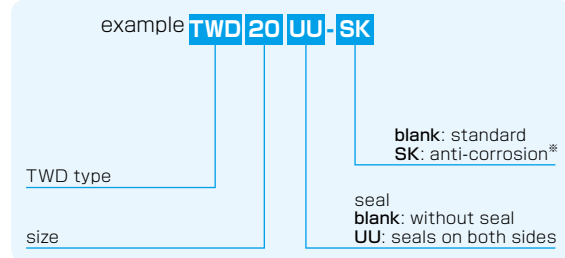

※For anti-corrosion the load plates are electroless nickel plated with stainless steel balls.

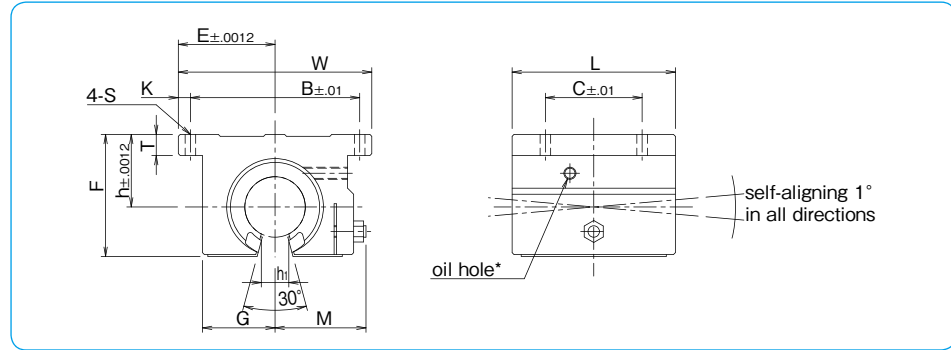

part number	nom. shaft dia. inch	major dimensions									mounting dimensions				basic load rating		mass
		h	E	W	L	F	T	G	M	h ₁	B	C	K	S	C	Co	
TWD 8UU	1/2	.6870	1.000	2.000	1.500	1.100	.250	.688	.86	.260	1.688	1.000	.156	.156	230	290	.188
TWD 10UU	5/8	.8750	1.2500	2.500	1.750	1.405	.281	.875	1.06	.319	2.125	1.125	.188	.188	400	500	.365
TWD 12UU	3/4	.9370	1.3750	2.750	1.875	1.535	.315	.937	1.12	.386	2.375	1.250	.188	.188	470	590	.452
TWD 16UU	1	1.1870	1.6250	3.250	2.625	1.975	.375	1.188	1.40	.512	2.875	1.750	.188	.218	850	1060	1.010
TWD 20UU	1-1/4	1.5000	2.0000	4.000	3.375	2.485	.437	1.500	1.88	.596	3.500	2.000	.250	.218	1230	1530	1.980
TWD 24UU	1-1/2	1.7500	2.3750	4.750	3.750	2.910	.500	1.750	2.12	.681	4.125	2.500	.313	.281	1480	1850	2.950
TWD 32UU	2	2.1250	3.0000	6.000	4.750	3.660	.625	2.250	2.70	.933	5.250	3.250	.375	.406	2430	3040	5.840

* Provided with push-in oil fitting for 1/2" size only. Sizes from 5/8" to 2" offer a 1/4-28 tapped hole with a plug for adding a fitting if desired.

1inch=25.4mm
1lbs≐0.454kg
1lbf≐4.448N

TWD-W TYPE (Inch Standard)

– Double-Wide Open Block Type –

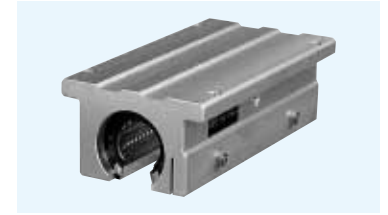

part number structure

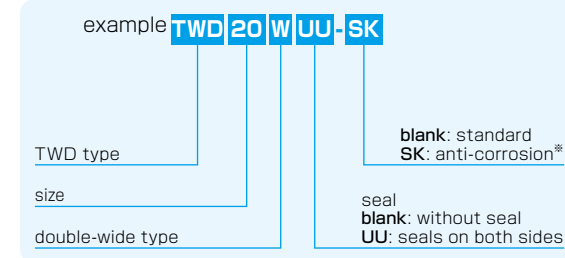

※For anti-corrosion the load plates are electroless nickel plated with stainless steel balls.

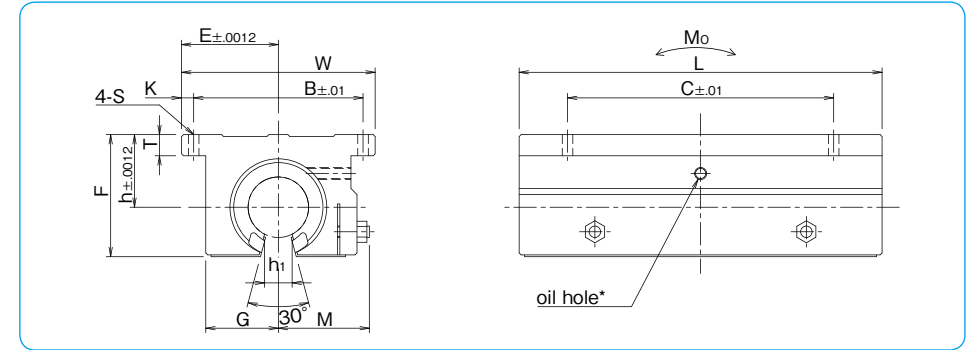

part number	nom. shaft dia. inch	major dimensions									mounting dimensions				basic load rating		allowable static moment		mass
		h	E	W	L	F	T	G	M	h ₁	B	C	K	S	C	Co	Mo	lbf·in	
TWD 8WUU	1/2	.6870	1.000	2.000	3.500	1.100	.250	.688	.86	.260	1.688	2.500	.156	.156	370	580	128	.400	
TWD 10WUU	5/8	.8750	1.2500	2.500	4.000	1.405	.281	.875	1.06	.319	2.125	3.000	.188	.188	640	1000	164	.800	
TWD 12WUU	3/4	.9370	1.3750	2.750	4.500	1.535	.315	.937	1.12	.386	2.375	3.500	.188	.188	750	1180	283	1.000	
TWD 16WUU	1	1.1870	1.6250	3.250	6.000	1.975	.375	1.188	1.40	.512	2.875	4.500	.188	.218	1360	2120	719	2.000	
TWD 20WUU	1-1/4	1.5000	2.0000	4.000	7.500	2.485	.437	1.500	1.88	.569	3.500	5.500	.250	.218	1970	3060	1200	4.200	
TWD 24WUU	1-1/2	1.7500	2.3750	4.750	9.000	2.910	.500	1.750	2.12	.681	4.125	6.500	.313	.281	2370	3700	1650	6.700	

* Provided with push-in oil fitting for 1/2" size only. Sizes from 5/8" to 1-1/2" offer a 1/4-28 tapped hole with a plug for adding a fitting if desired.

1inch=25.4mm
1lbs≐0.454kg
1lbf≐4.448N
1lbf·in≐0.112N·m