



MINIRAIL

Profiled miniature guideway

Table of Contents

1 Product overview and technical informations	
MINIRAIL – a range of high-precision products	2
MINIRAIL – overview accuracy classes:	3
MINIRAIL – overview preload categories	3
MINIRAIL – carriage replacement warranty	3
2 MINIRAIL – Technical highlights	
Accelerations	4
Lubrication	4
Ball retention	5
Protection against pollution	5
Materials	6
Vacuum capacity	6
Packaging	6
Smoothness and displacement force	7
Clamping element for safety purposes	7
3 Technical Data	
Accuracy classes	8
Running accuracy	8
Preload classes V0, V1	8
Rail lengths	9
Tolerances for rail lengths and fixing holes	9
Lubrication	10
Lubrication with grease	10
Lubrication with oil	10
Re-lubrication	10
Permissible speeds and accelerations	11
Permissible operating temperatures	11
Materials	11
Dimension table, loading capacities	12/13
Accessories and options	14
Plastic plugs	14
Multi-part rails (ZG)	14
4 Sizing and installation guidelines	
Dynamic loading capacity C	15
Tightening torques for rails and carriages	16
Configuration of the lateral location sides	17
Configuration of assembly surfaces	17
Geometrical and position accuracy of the support surfaces	18
Parallelism tolerances of the locating surfaces	19
Mounting instructions	19
As delivered condition	19
Transportation and intermediate storage	19
5 Ordering information MINIRAIL	20

MINIRAIL - a range of high-precision guideways

MINIRAIL represents the latest generation of miniature guideways for sophisticated applications. They are extremely robust, and their smooth running, precision, and reliability are demonstrated in every application.

The design, material selection, and surface finish of the recirculation element and ball entry zone guarantee low pulsation and therefore a smooth ride.

Rail Length L₃

Our manufacturing know-how supports high-precision manufacturing of rails up to 1000 mm in length, which can be offered in graded lengths.

The **range** includes eight rail widths. The following carriage sizes are available to select from:

Standard, short	MNNS 7	MNNS 9	MNNS 12	MNNS 15
Standard	MNN 7	MNN 9	MNN 12	MNN 15
Standard, long	MNNL 7	MNNL 9	MNNL 12	MNNL 15
Standard, x-long	MNNXL 7	MNNXL 9	MNNXL 12	MNNXL 15
Wide	MNN 14	MNN 18	MNN 24	MNN 42
Wide, long	MNNL 14	MNNL 18	MNNL 24	MNNL 42

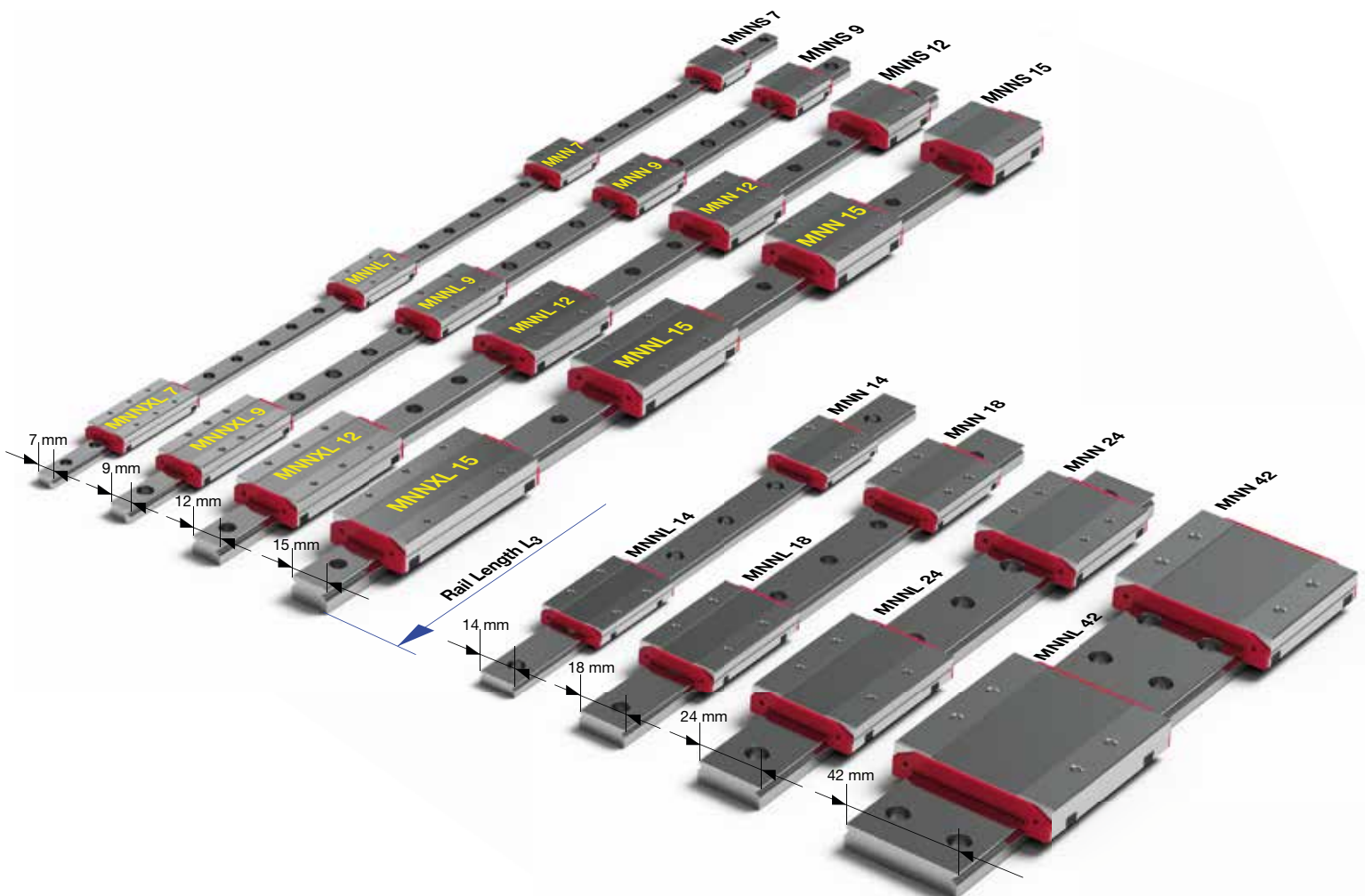

MINIRAIL in two accuracy grades: G3 and G1

Depending on the requirements of your application, you have the choice of two accuracy grades: precision G3 and high-precision G1.

Tolerances:

	A / B ₂	ΔA / ΔB ₂
G1, high-precision	± 10 μm	7 μm
G3, precision	± 20 μm	15 μm

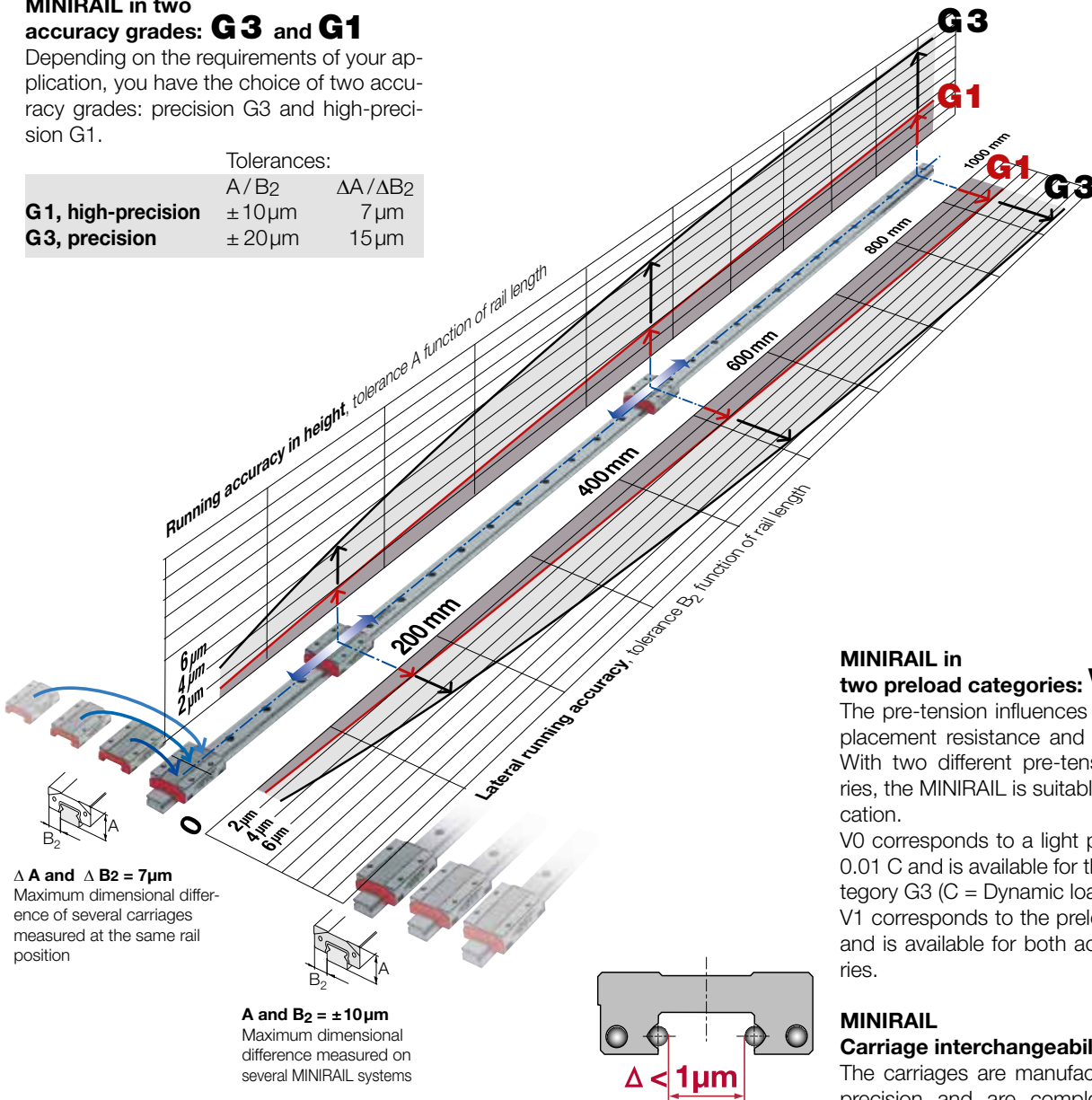

Δ A and Δ B₂ = 7 μm
Maximum dimensional difference of several carriages measured at the same rail position

A and B₂ = ± 10 μm
Maximum dimensional difference measured on several MINIRAIL systems

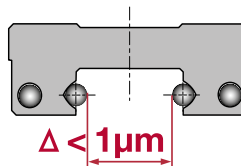

μm - accuracy

Our manufacturing control of this precise dimension is decisive for the complete interchangeability of the carriages.

MINIRAIL in two preload categories: V0 and V1

The pre-tension influences the rigidity, displacement resistance and service lifetime. With two different pre-tensioning categories, the MINIRAIL is suitable for your application.

V0 corresponds to a light preload of up to 0.01 C and is available for the accuracy category G3 (C = Dynamic load).

V1 corresponds to the preload 0 to 0.03 C and is available for both accuracy categories.

MINIRAIL Carriage interchangeability guarantee

The carriages are manufactured with high precision and are completely interchangeable. This makes a high degree of flexibility with respect to operations planning, stocking and assembly. As a result of the interchangeability, additional carriages can be installed onto an existing rail.

MINIRAIL – Technical highlights

2

High accelerations of up to 300 m/s²

The recirculation element plays a crucial role in withstanding the constantly increasing acceleration values. For this reason, SCHNEEBERGER uses a plastic material that is capable of enduring very high loads. The ingenious shape and the smooth surfaces of the recirculation element are designed with high levels of centrifugal force in mind.

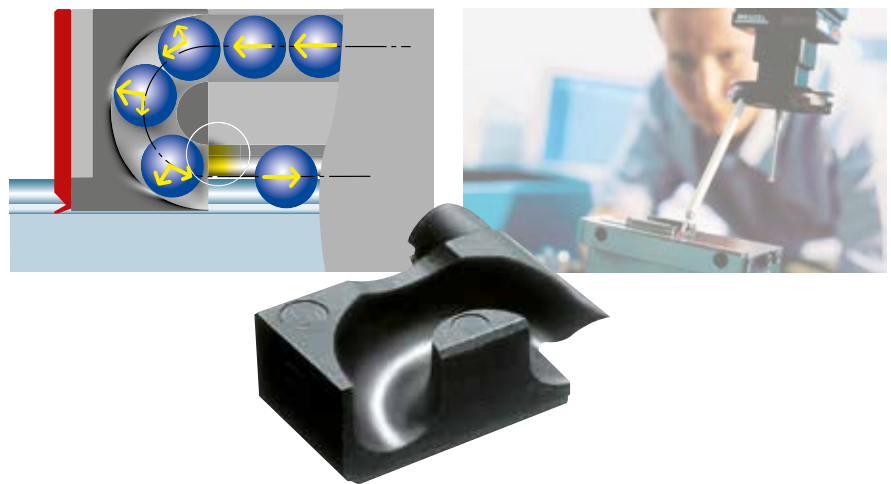

Direct lubrication

Two lubrication bores in each front plate allow the direct lubrication on the ball recirculation system.

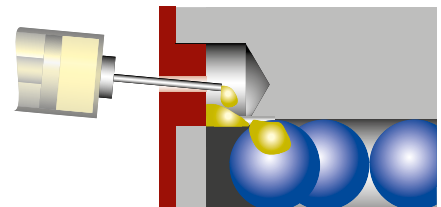

Ball retention device for easy handling

If a carriage is removed from the rail or is being prepared for installation, the balls are always retained in the carriage by a special ball retaining device. This makes handling significantly easier and is prerequisite for quickly changing the carriages.



Protection against dirt

To obtain quietness and extended life, rail and carriage assemblies require clean running surfaces - even under unfavorable conditions. Therefore our MINIRAIL carriages are equipped with rail-wiping, contoured front plates. Should the protective - and wiping function of the front plates not be required, the front plates can be removed easily. As a result, the displacement resistance is reduced significantly.



Plastic plugs in the rail mounting holes prevent the accumulation of any dirt.

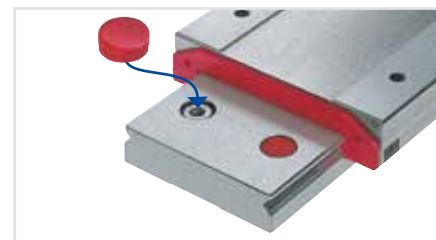

Tight clearances between the carriage and rail prevent dirt penetration.



High-grade materials

All rails and carriages are manufactured from corrosion-resistant, through-hardened steel and are suitable for utilization in the most diverse applications.



Vacuum capacity

MINIRAIL can be operated in high vacuum without any wiper (max. 10^{-7} mbar).

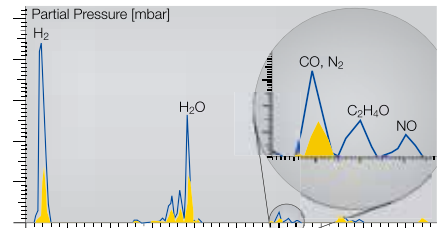

Protective packaging

Carriages and rails are packed carefully and ready for installation. In the process MINIRAIL carriages are shipped on a protective rail, in order to prevent any impairment by dirt or debris.



High smoothness and low displacement force

The precise fine grinding of the ball entry position on the running track is crucial to the operational quietness and service life, especially in the case of carriages with preload. Here we have indeed produced our best work.



Clamping element for safety purposes

The clamping element has been developed especially for MINIRAIL. In normal operation, the clamping element is maintained in an open position by compressed air, and in the case of an electric power failure, the spring-force blocks all movement for operational safety.

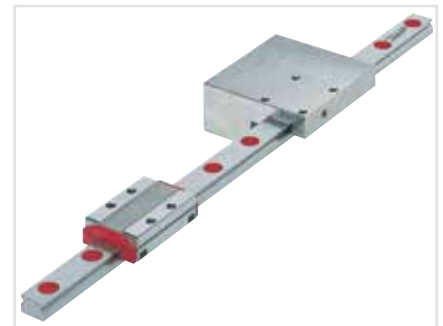

www.zimmer-gmbh.de

Accuracy classes

The MINIRAIL guideways are available in two accuracy classes.

Accuracy class	Tolerances	
	¹ A and B ₂	² Δ A and ΔB ₂
G1	± 10 μm	7 μm
G3	± 20 μm	15 μm

¹ Measuring referring to the center of the carriage
² Dimension differences between two or more carriages measured at the middle of each carriage (mean value of both supports) and at the same rail position

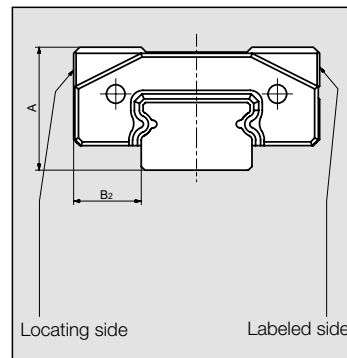

Running accuracy

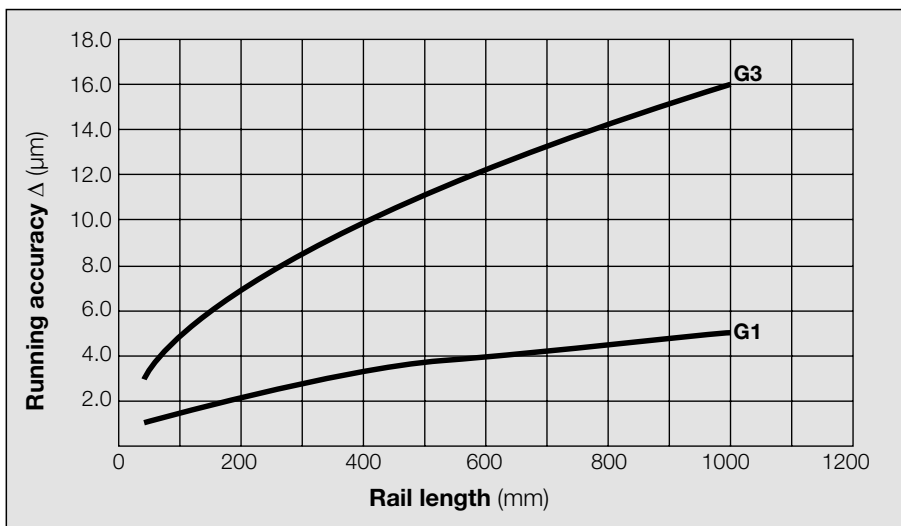

Preload classes V0 and V1

Preloading increases the rigidity of the guideway but also affects operational life and increases translation resistance. The MINIRAIL system is available in two preload classes to address specific application requirements. The rail up to determines the preload classes.

Preload class	Preload	Accuracy class
V0	near clearance to 0.01 · C	G3
V1	0 to 0.03 · C	G1, G3

C = Dynamic loading capacity (see page 13)

Rail lengths

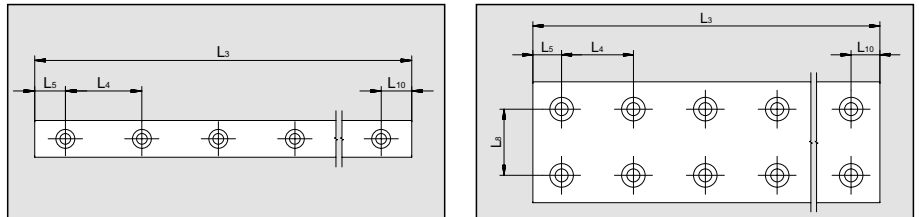

Standard rail lengths L_3 (length in mm)					
Size	L_4	L_5, L_{10}	L_8	L_3	Max L_3
7	15	5	–	40, 55, 70, 85, ...	1000
9	20	7.5	–	55, 75, 95, 115, ...	995
12	25	10	–	70, 95, 120, 145, ...	995
15	40	15	–	70, 110, 150, 190, ...	990
14	30	10	–	80, 110, 140, 170, ...	980
18	30	10	–	80, 110, 140, 170, ...	980
24	40	15	–	110, 150, 190, 230, ...	990
42	40	15	23	110, 150, 190, 230, ...	990

Custom rail lengths

Other rail lengths are available up to the maximum rail lengths above and are calculated according to the following formula:

$$L_3 = (n-1) \cdot L_4 + L_5 + L_{10} \quad n = \text{number of fixing holes}$$

The following minimum and maximum values should be maintained for the starting hole pitch L_5 and the end hole pitch L_{10} .

Minimum and maximum starting and end hole pitch L_5, L_{10} (lengths in mm)								
Size	7	9	12	15	14	18	24	42
L_5, L_{10} minimum	4	5	5	5	5	5	6	6
L_5, L_{10} maximum	11	15	20	35	25	25	34	34

Tolerances for rail lengths and fixing holes

The position tolerance of the attaching holes and the length tolerance is:

Rail	$L_3, X_n \leq 300$ mm	$L_3, X_n > 300$ mm
t (mm)	0.3	$0.001 \cdot X_n$
L_3	± 0.3	$\pm 0.001 \cdot L_3$

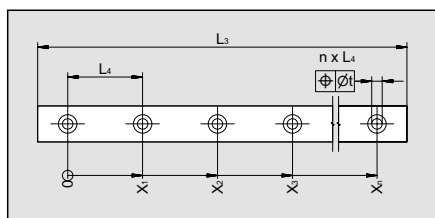

Lubrication

The front plates include two lubrication holes to allow independent lubrication for the right and left side of the carriage. This ensures that all tracks of the carriage are provided with lubricant, in all installation orientations.

At delivery the carriages are slightly oiled. Prior to operation the carriages must be lubricated! Subsequent lubrication depends upon environmental conditions as well as the nature and type of the load. Guarantees regarding subsequent lubrication intervals can only be provided through the user's own tests and experience. In all cases, the recommendations provided by the lubricant manufacturer must be followed.

For lubrication with oil, SCHNEEBERGER recommends mineral oil CLP (DIN 51517) or HLP (DIN 51524) in the viscosity range of ISO VG32 to ISO VG150 in accordance with DIN 51519.

For lubrication with grease, SCHNEEBERGER recommends grease KP2K or KP1K in accordance with DIN 51825.

A re-lubrication set with an appropriate oil can be ordered at SCHNEEBERGER with the ordering code MNW.



Lubrication with grease

During the lubrication the carriages have to be moved on the rail in order to distribute the lubricant.

Quantity of grease in cm ³							
MNNS 7	MNNS 9	MNNS 12	MNNS 15				
0.03	0.05	0.09	0.16				
MNN 7	MNN 9	MNN 12	MNN 15	MNN 14	MNN 18	MNN 24	MNN 42
0.04	0.09	0.15	0.25	0.05	0.11	0.20	0.33
MNNL 7	MNNL 9	MNNL 12	MNNL 15	MNNL 14	MNNL 18	MNNL 24	MNNL 42
0.05	0.11	0.20	0.35	0.07	0.14	0.26	0.45
MNNXL 7	MNNXL 9	MNNXL 12	MNNXL 15				
0.07	0.14	0.26	0.45				

Lubrication with oil

During the lubrication the carriages have to be moved on the rail in order to distribute the lubricant.

Re-lubrication

Guideline values based on the following assumption:

- Load ratio $C/P^* = 10$
 - Speed of 1 m/s
 - Stroke of 150 mm
- Re-lubrication interval = 3000 km

*C = dynamic loading capacity / P = equivalent force

**Permissible speeds
and accelerations**

General applications under normal operating conditions:

Speeds up to	5 m/s
Accelerations up to	300 m/s ²

**Permissible operating
temperatures**

MINIRAIL guideways can be used at operating temperatures between -40°C and +80°C. Short term temperatures up to +120°C are permissible.

Materials

All steel parts are made from through hardened stainless steel. Plastic components are injection-molded using POM and TPE.

Types: 7, 9, 12, 15, 14, 18, 24

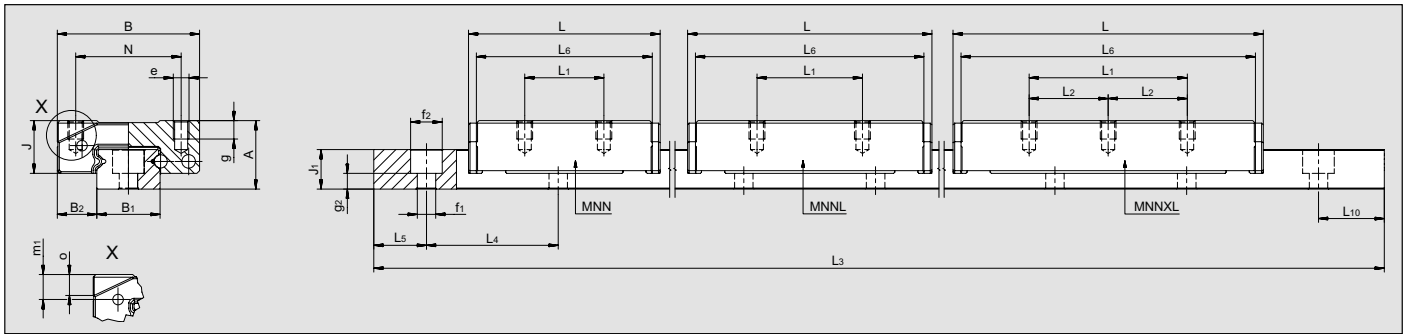

Dimension table, loading capacities

Type		Dimensions (mm)																				
Rail	Carriage	A	B	B ₁	B ₂	J	J ₁	L	L ₁	L ₂	L ₄	L ₅ /L ₁₀	L ₆	L ₈	N	e	f ₁	f ₂	g	g ₂	m ₁	o
MN 7	MNNS 7	8	17	7	5	6.5	4.5	18.6	-	-	15	5	16.1	-	12	M2	2.4	4.2	2.5	2.2	3.1	2.5
	MNN 7							24.6	8	-			22.1									
	MNNL 7							32.1	13	-			29.6									
	MNNXL 7							41.1	20	10			38.6									
MN 9	MNNS 9	10	20	9	5.5	8	5.5	22	-	-	20	7.5	19	-	15	M3	3.5	6	3	2	3.8	3.1
	MNN 9							32	10	-			29									
	MNNL 9							40	16	-			37									
	MNNXL 9							50	26	13			47									
MN 12	MNNS 12	13	27	12	7.5	10	7.5	23.9	-	-	25	10	20.9	-	20	M3	3.5	6	3.5	3	4.75	3.9
	MNN 12							36.4	15	-			33.4									
	MNNL 12							46.4	20	-			43.4									
	MNNXL 12							58.9	30	15			55.9									
MN 15	MNNS 15	16	32	15	8.5	12	9.5	31.7	-	-	40	15	28.7	-	25	M3	3.5	6	4	5	5.55	4.9
	MNN 15							43.7	20	-			40.7									
	MNNL 15							58.7	25	-			55.7									
	MNNXL 15							73.7	40	20			70.7									
MN 14	MNN 14	9	25	14	5.5	6.8	5.2	32.1	10	-	30	10	29.6	-	19	M3	3.5	6	2.8	2	3.3	2.2
	MNNL 14							41.1	19	-			38.6									
MN 18	MNN 18	12	30	18	6	8.5	7	40	12	-	30	10	37	-	21	M3	3.5	6	3	2.5	4.3	3.1
	MNNL 18							50	24	-			47									
MN 24	MNN 24	14	40	24	8	10	8.5	46.4	15	-	40	15	43.4	-	28	M3	4.5	8	3.5	4	4.75	3.9
	MNNL 24							58.9	28	-			55.9									
MN 42	MNN 42	16	60	42	9	12	9.5	55.7	20	-	40	15	52.7	23	45	M4	4.5	8	4.5	5	5.5	4.9
	MNNL 42							73.7	35	-			70.7									

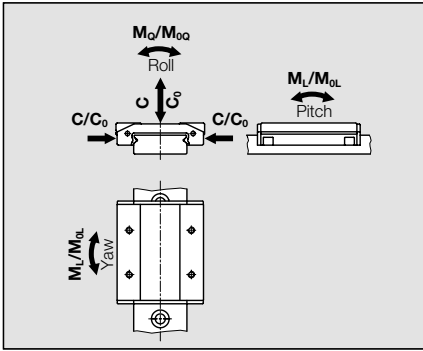

Loading capacities are calculated values, based on DIN 636-2
 C_0 = static loading capacity
 C = dynamic loading capacity (100 km)
 M_0 = static moment
 M = dynamic moment (100 km)

Type: 42

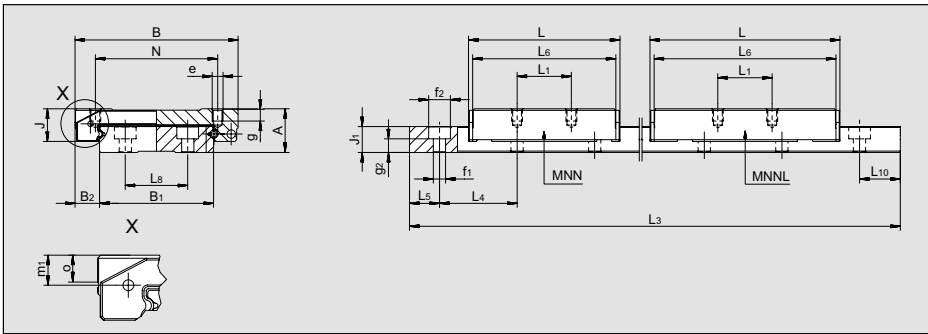

	Loading capacities		Moments				Weights	
	C_0 (N)	C (N)	M_{0Q} (Nm)	M_{OL} (Nm)	M_Q (Nm)	M_L (Nm)	Carriage (g)	Rail (g/m)
	935	645	3.4	1.6	2.3	1.1	9	216
	1560	925	5.6	4.3	3.3	2.5	13	
	2340	1230	8.4	9.3	4.4	4.9	18	
	3275	1550	11.8	17.4	5.6	8.2	23	
	1385	1040	6.5	2.8	2.8	4.8	16	309
	2770	1690	12.9	10.2	7.9	6.2	24	
	3880	2140	18.1	19.4	9.9	10.7	31	
	5270	2645	24.5	34.5	12.3	17.3	40	
	1735	1420	10.6	3.6	8.7	3	29	598
	3900	2510	23.8	16.3	15.3	10.4	47	
	5630	3240	34.4	32.9	19.8	18.9	63	
	7800	4070	47.6	61.1	24.8	31.9	81	
	3120	2435	23.7	9.4	18.5	7.3	56	996
	5620	3680	42.7	28.1	27.9	18.4	81	
	8740	5000	66.4	65.5	38.1	37.6	114	
	11855	6200	90.1	116.5	47.1	60.9	146	
	2340	1230	16.6	9.3	8.7	4.9	25	518
	3275	1550	23.3	17.4	11	8.2	33	
	3880	2140	35.5	19.4	19.6	10.7	47	915
	5270	2645	48.2	34.5	24.2	17.3	60	
	5630	3240	68.2	32.9	39.2	18.9	84	1473
	7800	4070	94.4	61.1	49.3	31.9	109	
	8110	4750	171.2	56.8	100.3	33.3	169	2828
	11855	6200	250.2	116.5	130.8	60.9	231	

Accessories and options

Plastic plugs

Plastic plugs can be used to close the rail attachment holes.

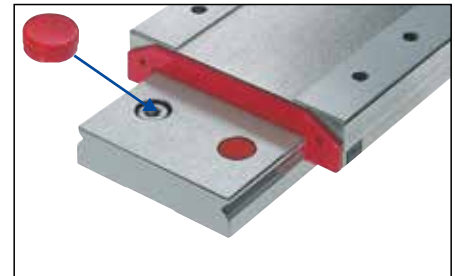

MINIRAIL Typ	Plastic plugs Typ	Plastic plugs can be combined with attaching screws of type		
		DIN 912	DIN 7984	DIN 7380
MN 7	MNK 4	-	-	X
MN 9	MNK 6	-	X	X
MN 12	MNK 6	X	X	X
MN 15	MNK 6	X	X	X
MN 14	MNK 6	-	X	X
MN 18	MNK 6	X	X	X
MN 24	MNK 8	-	X	X
MN 42	MNK 8	-	X	X

Multi-section rails (ZG)

Should the desired overall length of the rail exceed the maximum length specified in the brochure, some rails can be ground together. The offset between the individual guide rails does not exceed 0.002 mm. When assembling the guideways, the numbering at the junction must be observed.

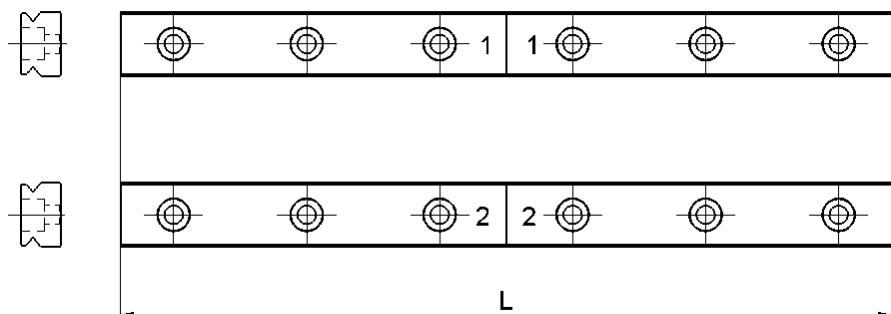

Sizing and installation guidelines

Dynamic loading capacity C

The loading capacity values for anti-friction guideways are based on the principles specified by the ISO for calculation of rolling-contact bearings (DIN ISO 281).

Dynamic loading capacity is the loading which results in a nominal operational life corresponding to a translation distance of 100 000 m (100 km) provided that the loading due to mass and direction is unchanged and the line of influence acts vertically on the rolling-contact bearing unit.

Other suppliers often indicate their loading capacities for a translation distance of 50 000 m (50 km). These values according to JIS standard are above the values according to DIN ISO. The recalculation of the loading capacities is done as follows:

$$C_{50} = 1.26 \cdot C_{100}$$

Operational life calculation

The nominal calculated operational life L for the equivalent force P and a dynamic loading capacity C is:

$$L = (C/P)^3 \cdot 10^5 \text{ m} \quad L = \text{nominal life (m)}$$

Operational life calculation in hours

$$L_h = \frac{L}{2 \cdot s \cdot n \cdot 60} = \frac{L}{60 \cdot v_m}$$

L_h = nominal life (h)
 s = stroke length (m)
 n = stroke frequency (min⁻¹)
 v_m = average traversing speed (m/min)

**Tightening torques for rails
and carriages**

**Tightening torques for fastening screws DIN 912, μ 0,125 (12,9)
and DIN 912, μ 0,2 (A2-70)**

Strengthclass	max. tightening torques [Nm]		
	M2	M3	M4
12.9	0.6	2.1	5.0
A2-70	0.3	1.1	2.6

Notes

When the screws are greased with grease containing MoS₂ the friction coefficient μ can be reduced by as much as half. As the tightening torques required to reach the maximum permissible tightening force depend on the friction coefficient, they must be reduced accordingly. The values can be obtained from the screw manufacturer's information or from the specialist literature. If necessary, carry out tests to determine the actual friction coefficient.

Refer to the screw manufacturer's information. This is always binding.

Configuration of the lateral locating sides

The corners between the support and locating surfaces of the surrounding structure are normally provided with a relief groove. However, if no relief groove is provided, then the dimensions tabulated below must be maintained.

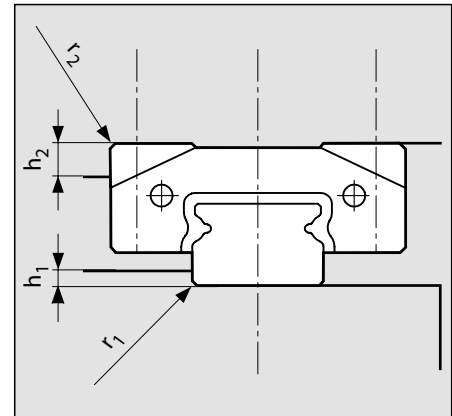

Size	h_1	r_1 max	r_2 max	h_2
7	1.2	0.2	0.3	2.5
9	1.5	0.3	0.4	3
12	2.5	0.4	0.4	4
15	3.5	0.5	0.5	5
14	1.8	0.2	0.4	2
18	3	0.3	0.5	3
24	3.5	0.4	0.5	4
42	3.5	0.5	0.6	5

Configuration of assembly surfaces

MINIRAIL advantages can only be achieved when mounted to a rigid, accurately machined structure.

A roughness average ratio of R_a 0.4 to 1.6 μm is recommended for support and locating surfaces.

Inaccuracies of the attachment surfaces are partially compensated by the elastic deformation of the MINIRAIL. However, they may affect overall accuracy, running behavior and operational life.

Geometrical and position accuracy of the support surfaces

Admissible height difference E_1 (use values in mm for the calculation)

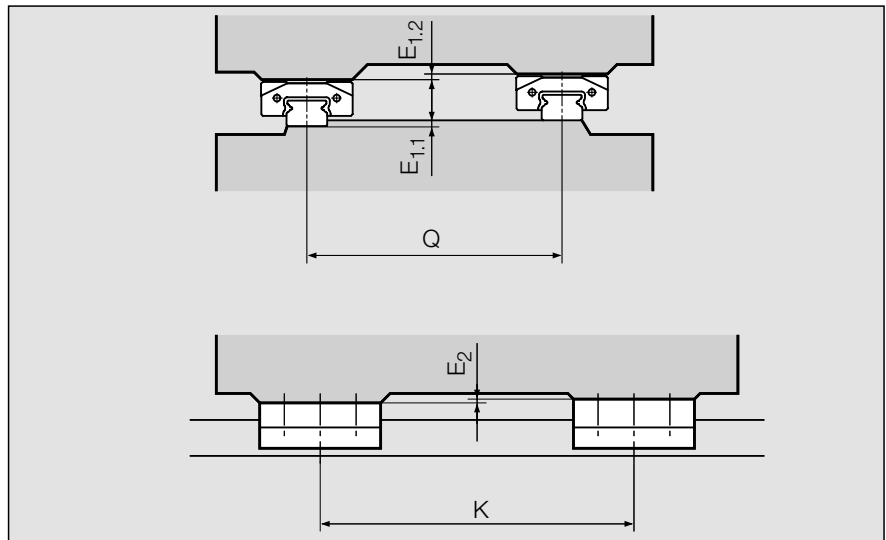

Size	Preload	
	VO	V1
MNNS, MNN, MNNL, MNNXL		
E1 = E1.1 + E1.2	7, 9, 12, 15	0.00025 Q 0.00015 Q
E1 = E1.1 + E1.2	14, 18, 24, 42	0.00013 Q 0.00008 Q
MNNS		
E2	7, 9, 12, 15	0.00010 K 0.00010 K
MNN		
E2	7, 9, 12, 15	0.00005 K 0.00005 K
E2	14, 18, 24, 42	0.00004 K 0.00004 K
MNNL		
E2	7, 9, 12, 15	0.00004 K 0.00004 K
E2	14, 18, 24, 42	0.00003 K 0.00003 K
MNNXL		
E2	7, 9, 12, 15	0.00003 K 0.00003 K

Example of calculation

Nominal: Type MNN 12
 Preload class V1
 Gap Q 120 mm

Target: Admissible height difference E_1

Calculation: $0.00015 \times 120 \text{ mm} = \underline{0.018 \text{ mm}}$

Result: The difference of $E_{1,1}$ plus $E_{1,2}$ ($= E_1$) must not exceed 0.0180 mm.

Parallelism tolerances of the locating surfaces

Permissible tolerances for the parallelism

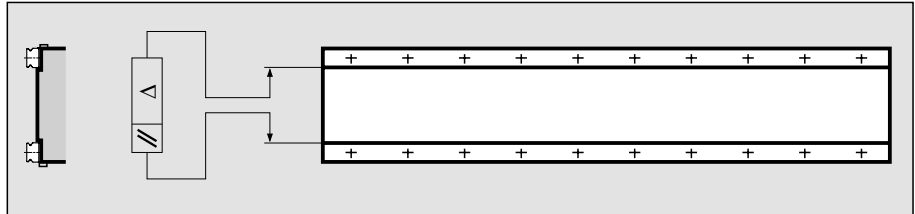

Tolerances for preload class (mm)				
	7 / 14	9 / 18	12 / 24	15 / 42
V0	0.003	0.005	0.008	0.01
V1	0.002	0.003	0.004	0.005

Mounting instructions

The installation of the MINIRAIL guideways is described in detail in the separate **Mounting Instructions MINIRAIL** and can be downloaded from www.schneeberger.com at menu DOWNLOADS.

As delivered condition

MINIRAIL are delivered in protective packaging. The carriages are mounted on a plastic rail and slightly oiled for immediate operation.



Transportation and intermediate storage

MINIRAIL are highly precise components, which have to be treated with care. As a protection against damage, the following instructions should be followed:

- Always store and transport MINIRAIL in their original packaging.
- Protect the guideways against impacts and dampness/humidity.

Ordering information MINIRAIL

The MINIRAIL carriage and rail must be ordered as separate items.

		Ordering example:	___	MNN	12	-G3
Carriage						
Quantity	___					
Carriage type	MNNS**, MNN, MNNL, MNNXL**					
Size	7, 9, 12, 15, 14, 18, 24, 42					
Accuracy class	G1, G3					

** Not available for sizes 14, 18, 24 and 42

		Ordering example:	___	MN	9	-155	-7.5	-7.5	-G1	-V1	-ZG
Rail											
Quantity	___										
Rail type	MN										
Size	7, 9, 12, 15, 14, 18, 24, 42										
Rail length	L₃ (in mm)										
Starting hole pitch	L₅ (in mm)*										
End hole pitch	L₁₀ (in mm)*										
Accuracy class	G1, G3										
Preload class	V0, V1										
Multi-part rails	ZG										

* Indicate only if special pitch

Accessories

		Ordering example:	___	MNW
Re-lubrication set				
Quantity	___			
Type	MNW			

		Ordering example:	___	MNK	6
Plastic plugs					
Quantity	___				
Type	MNK				
Size	4, 6, 8				

SCHNEEBERGER AGENCIES

EUROPE

AUSTRIA

Haberkorn GmbH
6961 Wolfurt
Phone: +43 5574 695-0
Fax: +43 5574 695-99
info.wolfurt@haberkorn.com

BULGARIA / MACEDONIA

Atlas Technik EOOD
Hippodroma, Bl. 139B, Eing. A, App. 6
1612 Sofia, PB 51
Bulgarien
Phone +359 2 859 76 81
Fax +359 2 859 76 81
Mobil +359 8 852 32 595
E-Mail: al_popoff@techno-link.com

CROATIA

Haberkorn CRO d.o.o.
10431 Sveta Nedelja
Phone +385 1 333 5870
Fax +385 1 337 3902
E-Mail: info@haberkorn.hr

DENMARK

HERSTAD + PIPER A/S
Jernholmen 48c
2650 Hvidovre
Phone +45 367 740 00
Fax +45 367 777 40
E-Mail: mail@herstad-piper.dk

FINLAND

EIE Maskin OY
PL, 80 Asematie 1
10601 Tammissaari
Phone +358 192 239 100
Fax +358 192 239 199
E-Mail: info@eie.fi

FRANCE

Region Rhône-Alpes
Groupe BARET
6 avenue du 11 novembre 1918
69200 Venissieux
Phone +33 4 78 77 32 32
Fax +33 4 78 00 90 00
E-Mail: contact@baret.fr

Regions Ile de France, Normandie, Bretagne

Groupe LECHEVALIER
56 rue Jean Mermoz
Parc d'activités de la Bretèque
76230 Bois-Guillaume Cedex
Phone +33 2 35 12 65 65
Fax +33 2 35 59 89 97
E-Mail: contact@lechevalier-sa.com

Region Nord Pas de Calais

LEFRANC LTL «Le Panetier»
35, rue Pierre Martin
Parc d'Activités de l'Inquétre
62280 Saint Martin Boulogne
Phone +33 3 21 99 51 51
Fax +33 3 21 99 51 50
E-Mail: lefranc.boulogne@lefranc-sa.fr

GERMANY

BGP-Blazevic Geradlinige Präzisionstechnik
Stipo Blazevic
Hochstiftstrasse 31
93055 Regensburg
Phone +49 941 569 996 20
Fax +49 941 569 950 97
Mobil +49 151 401 126 25
E-Mail: info@bpg-blazevic.de

GREAT BRITAIN

LG Motion Ltd.
Unit 1 Telford Road
Houndmills Estate, Basingstoke
Hampshire RG21 6YU
Phone +44 012 563 656 00
Fax +44 012 563 656 45
E-Mail: info@lg-motion.co.uk

EUROPE

HUNGARY

Haberkorn Kft.
Asztalos Sándor u.12
Budapest, 1087
Phone +36 13030325
Fax +36 1/3030262
E-Mail: office@haberkorn.rs

ITALY

Nadella S.r.l.
Via Melette, 16
20128 Milano
Phone +39 022 709 329 7
Fax +39 022 551 768
E-Mail: customer.service@nadella.it

NORWAY

Elmeko AS (s. EIE Maskin)
Tvetenveien 164
0671 Oslo
Phone +47 675 722 70
Fax +47 675 722 80
E-Mail: elmeko@elmeko.no

POLAND

TECHNIKA LINIOWA
Rollico Rolling Components
Ul. Cegielniana 21
42-700 Lubliniec
Phone +48 343 510 430
Fax +48 343 510 431
E-Mail: rollico@rollico.com

ROMANIA

Meximpex SRL
4, Burebista Blvd.,
bl. D13 sc. A et 2 ap. 9-10
031108 Bucharest
Phone +40 213 166 843 /44
Fax +40 213 166 846
E-Mail: office@meximpex.ro

SERBIA/MONTENEGRO

Haberkorn d.o.o.
Kralja Petra I, 59
21203 Veternik,
Phone +381 21 3 101 555
Fax +381 21 3 101 554
E-Mail: office@haberkorn.rs

SLOVAKIA

KBM, s.r.o.
Juraj Hajovsky
Zitná 13
010 04 Zilina
Phone +421 417 070 324
Fax +421 417 070 333
Mobile +421 090 585 1465
E-Mail: jhajovsky@kbn.sk

SLOVENIA / BOSNIA HERZEGOVINA

Haberkorn d.o.o.
Vodovodna ul. 7
2000 Maribor
Phone +386 2 320 67 10
Fax +386 2 320 67 30
E-Mail: info@haberkorn.si

SWEDEN

EIE Maskin AB
Box 7
12421 Bandhagen
Phone +46 87 278 800
Fax +46 87 278 899
E-Mail: eie@eie.se

TURKEY

Birlik Rulman (Paz.ltd.sti.)
Mumhane Cad. No: 16
80030 Karakoy-Istanbul
Phone +90 212 249 54 95
Fax +90 212 244 21 40
E-Mail: birlik@birlikrulman.com

ASIA

KOREA

Intech Automation Inc.
1-1108, Ace Hitech City
55-20 Mullaee-Dong 3-Ga
Youngdeungpo-Ku
150-972 Seoul
Phone +82 2 3439 0070 - 4
Fax +82 2 3439 0080
E-Mail: intech@intechautomation.co.kr

Lineartech Inc.

369 Geumgok-ri, Dongtan-myeon
Hwaseong-si, Gyeonggi-do
445-811 Korea
Phone +82 31 274 0485
Fax +82 31 274 0486
E-Mail: lineartech@chol.com

TAIWAN / REPUBLIC OF CHINA

Ever Bright Precisiton Ltd.
1 F,nr.52
Lane 10 Chi-hu Road
114 Taipei
Phone +886 226 595 586
Fax +886 226 595 587
E-Mail: sales@everbright.com.tw

AUSTRALIA / NEW ZEALAND

RJM Engineering Supplies
Tamar Street 13
VIC 3134 Ringwood
Phone +61 398 794 881
Fax +61 398 793 700
E-Mail: rjmeng@rjmeng.com.au

SOUTH AFRICA

Fischli & Fuhrmann Ltd.
P.O Box 253
1600 Isando Gauteng
Phone +27 119 745 571
Fax +27 119 745 574
E-Mail: info@fifu.co.za

SOUTH AMERICA

Ibatech Tecnologia Ltda.
Av. Amazonas, 976
90240 542 Porto Alegre RS
Brazil
Phone +55 513 337 14 81
Fax +55 513 337 52 65
E-Mail: ibacorp@iba-corp.com

PROSPECTUSES

- COMPANY BROCHURE
- CUSTOMIZED BEARINGS
- GEAR RACKS
- LINEAR BEARINGS and RECIRCULATING UNITS
- MINERAL CASTING SCHNEEBERGER
- MINI-X MINIRAIL / MINISCALE PLUS / MINISLIDE
- MONORAIL and AMS profiled linear guideways with integrated measuring system
- MONORAIL and AMS application catalog
- POSITIONING SYSTEMS
- SLIDES



SCHNEEBERGER COMPANIES

SWITZERLAND

SCHNEEBERGER AG
St. Urbanstrasse 12
4914 Roggwil/BE

Phone +41 62 918 41 11
Fax +41 62 918 41 00

E-Mail:
info-ch@schneeburger.com

JAPAN

Nippon SCHNEEBERGER K.K.
Crane Toranomon Bldg 7F
3-20-5 Toranomon, Minato-ku
Tokyo 105-0001

Phone +81 3 6435 7474
Fax +81 3 6435 7475

E-Mail:
info-j@schneeburger.com

JAPAN

日本シュネーベルガー株式会社
〒105-0001
東京都港区虎ノ門3-20-5
クレイン虎ノ門ビル7F

電話 03 6435 7474
ファクス 03 6435 7475

Eメール:
info-j@schneeburger.com

GERMANY

SCHNEEBERGER GmbH
Gräfenau
75339 Höfen/Enz

Phone +49 7081 782 0
Fax +49 7081 782 124

E-Mail:
info-d@schneeburger.com

CHINA

SCHNEEBERGER (Shanghai) Co., Ltd.
Rm 606, Shang Gao International
Building
No. 137 XianXia Road
200051 Shanghai

Phone +86 21 6209 0037 / 27
Fax +86 21 6209 0102

E-Mail:
info-cn@schneeburger.com

CHINA

施耐博格 (上海) 传动技术有限公司
上海市长宁区
仙霞路137号盛高国
际大厦606室, 上海 200051

电话 +86 21 6209 0027
传真 +86 21 6209 0102

邮箱:
info-cn@schneeburger.com

ITALY

SCHNEEBERGER S.r.l.
Via Soldani 10
21021 Angera (VA)

Phone +39 0331 93 2010
Fax +39 0331 93 1655

E-Mail:
info-i@schneeburger.com

KOREA

SCHNEEBERGER Korea Ltd.
UNION Center Building
1004, 10th FL
310, Gangnam-Daero,
Gangnam-Gu, Seoul,
Korea 135-754

Phone +82 2 554 2971
Fax +82 2 554 3971

E-Mail:
info-kr@schneeburger.com

KOREA

서울시 강남구 강남대로 310
유니온센터 빌딩 1004호
우편번호 135-754

전화 +82 2 554 2971
팩스 +82 2 554 3971

이메일:
info-kr@schneeburger.com

USA

SCHNEEBERGER Inc.
44 Sixth Road,
Woburn, MA 01801-1759

Phone +1 781 271 0140
Fax +1 781 275 4749

E-Mail:
info-usa@schneeburger.com

SINGAPORE

SCHNEEBERGER LINEAR
TECHNOLOGY PTE. Ltd.
160 Paya Lebar Road, #05-04
Orion Industrial Building
409022 Singapore

Phone + 65 6841 2385
Fax + 65 6841 3408

E-Mail:
info-sg@schneeburger.com

INDIA

SCHNEEBERGER India Pvt. Ltd.
406, 4th Floor, Satra Plaza,
Palm Beach Road, Sector 19D Vashi,
400 703 New Mumbai

Phone +91 22 6461 0646
+91 22 6461 1756

E-Mail:
info-in@schneeburger.com

SCHNEEBERGER MINERAL CASTING

CZECH REPUBLIC

SCHNEEBERGER
Mineralgusstechnik s.r.o
Prumyslový park 32/20
350 02 Cheb – Dolní Dvory

Phone +420 354 400 941
Fax +420 354 400 940

E-Mail:
info-mineralguss@schneeburger.com

CHINA

SCHNEEBERGER Changzhou
Precision Systems Co. Ltd.
137 Hanjiang Road
Changzhou New district
213000 Changzhou, Jiangsu

Phone +86 519 8988 3938
Fax +86 519 8988 5115

E-Mail:
info-mineralcasting@schneeburger.com

CHINA

施耐博格 (常州) 测试系统有限公司
汉江路137, 常州新区, 常州213022

电话 +86 519 8988 3938
传真 +86 519 8988 5115

邮箱:
info-mineralcasting@schneeburger.com

SCHNEEBERGER SALES DEPARTMENTS

AUSTRIA AND SOUTH EAST EUROPE

Mobile +43 676 935 1035

E-Mail:
info-a@schneeburger.com

BENELUX

Mobile +31 6 5326 3929

E-Mail:
info-nl@schneeburger.com

DENMARK, SWEDEN

Mobile +31 6 5326 3929

E-Mail:
info-nl@schneeburger.com

FRANCE

Mobile +33 6 0941 6269

E-Mail:
info-f@schneeburger.com

GREAT BRITAIN

Mobile +44 77 8814 5645

E-Mail:
info-uk@schneeburger.com

ISRAEL

Mobile +972 5 0551 7920

E-Mail:
info-il@schneeburger.com

POLAND, SLOVAKIA, CZECH REPUBLIC

Mobile +420 6 0278 4077

E-Mail:
info-cz@schneeburger.com

RUSSIA, BELARUS, UKRAINE

Mobile +7 985 960 85 53
Mobile +38 050 407 6789
Mobile +37 529 860 0410

E-Mail:
info-ru@schneeburger.com

SPAIN, PORTUGAL ANDORRA

Mobile +34 69 559 05 99

E-Mail:
info-es@schneeburger.com

TURKEY

Mobile +90 545 320 83 55

E-Mail:
info-tr@schneeburger.com

www.schneeburger.com